

Made in Italy

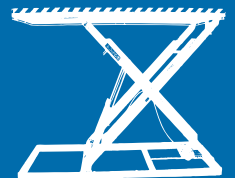

**DISSET
ODISEO**

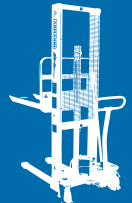

STACKERS - PALLET TRUCKS - TOW TRACTORS - LIFT TABLES - STAINLESS STEEL - CUSTOM SOLUTIONS

PALLET TRUCKS



TPM
 Kg 2000 - 2500 - 3000
 mm 200



TPM GAL 10 / TPM GAL 10 12V
 Kg 1000
 mm 800



SMART LIGHT evo / PLUS AC-evo
 Kg 1500 / 2000
 mm 200



SMART DL AC-evo
 Kg 1800/750 - 1800/1050
 mm 200/700 - 200/1400



DISCOVERY AC-evo
 Kg 2000 - 2500 - 3000 - 3500 - 4000
 mm 200



CHALLENGER AC-evo
 Kg 1500 - 2000
 mm 200



SKIPPER AC-evo
 Kg 1500 - 2000 - 2500 - 3000
 mm 200 / 200 - 850



MAJESTIC AC-evo
 Kg 1600 - 2000
 mm 200



TPE HL AC-evo
 Kg From 5000 to 20000
 mm On demand



DISCOVERY PB AC-evo
 Kg On demand
 mm On demand

TOW TRACTORS



TPT / TPT UB AC-evo
 Kg 4000 - 5000 - 6000
 mm On demand



TPT HL AC-evo
 Kg From 7000 to 20000
 mm On demand

LIFT TABLES



TM
 Kg 500 - 1000
 Manual



TE
 Kg 500 - 1000 - 1500 - 2000 - 2500
 Electric 220 / 380V



GAMMA 800 M
 Kg 800
 Manual



GAMMA 800 12V
 Kg 800
 Electric 12V

STAINLESS STEEL



STAINLESS STEEL PRODUCTION (Stackers, Pallet Trucks and Lift Tables)

CUSTOM SOLUTIONS



CUSTOMIZED SOLUTIONS FOR REELS, DRUMS AND ANY TYPE OF BOX-CONTAINER HANDLING

ALFA M evo

Manual movement and lifting for maximum comfort and simplicity when handling loads that are not particularly heavy.



ALFA SMALL 12V evo

Version with manual movement and electro-hydraulic elevation for quick lifting operations without operator's physical effort. Single-stage lifting mast for lift heights between 800 and 1600 mm.



ALFA 12V evo

Semi-electric version with two-stage mast for lift heights up to 3.5 meters.

Features in detail: _____



ADJUSTABLE FORKS:

Forks can be manually adjusted in the fork holder plate; a simple operation that allows using the same truck for loads that have different overall dimensions.



DRIVING HANDLES:

Side handles to assure easy maneuvering and positioning of the truck with manual movements.



MANUAL LIFTING (ALFA M evo):

Quick lift hand pump with lowering control installed in the same pump to facilitate a quick execution of every operation.



ELECTRO-HYDRAULIC LIFTING (12V versions):

Lifting and lowering control switches are installed in a protective casing. An Emergency Stop switch cuts the power supply.



ALFA M evo

model		55/08	105/08	25/16	55/16	105/16
Q	Kg	500	1000	250	500	1000
C	mm	600	600	400	400	400
I	mm	1150	1150	800	800	800
L	mm	1730	1730	1210	1380	1380
X	mm	400	400	130	200	200
Y	mm	1270	1270	1015	1120	1120
L2	mm	580	580	405	580	580
M	mm	200/800	240/800	200/800	200/800	240/800
N	mm	100	120	100	100	120
h1	mm	1230	1230	1990	1990	1990
h2	mm	800	800	1600	1600	1600
h3	mm	800	800	1600	1600	1600
h4	mm	1240	1240	1990	2000	2000
B	mm	800	800	800	800	800
E	mm	520	530	540	520	530
F	mm	405	350	415	405	350
S	mm	50	55	42	50	55
WA	mm	1320	1320	1050	1135	1135

STANDARD EQUIPMENT

- High free lift (simplex mast) • Lifting by fast manual pump (without load) • Descent by lever • Adjustable forks length 800 mm (1150 mm for 800 mm lifting height) • Parking Brake • Polyurethane single roller • Polyamide wheels with polyurethane covering • Safety components • Manual Traction

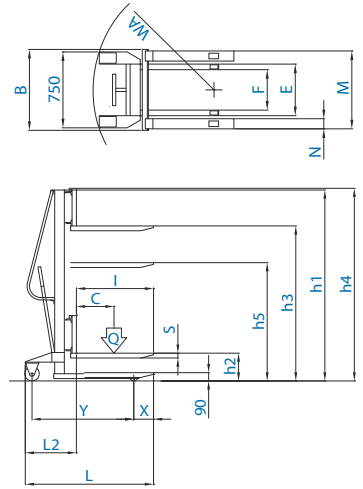

ALFA SMALL 12V evo

model		55/08	105/08	55/16	105/16
Q	Kg	500	1000	500	1000
C	mm	600	600	400	400
I	mm	1150	1150	800	800
L	mm	1730	1730	1380	1380
X	mm	400	400	200	200
Y	mm	1270	1270	1120	1120
L2	mm	580	580	580	580
M	mm	200/800	240/800	200/800	240/800
N	mm	100	120	100	120
h1	mm	1230	1230	1990	1990
h2	mm	800	800	1600	1600
h3	mm	800	800	1600	1600
h4	mm	1240	1240	2000	2000
B	mm	800	800	800	800
E	mm	520	520	520	530
F	mm	405	405	405	350
S	mm	50	55	50	55
WA	mm	1320	1320	1135	1135

STANDARD EQUIPMENT

- High free lift (simplex mast) • Built-in electronic battery charger 12V 10A with microprocessor • Forks control by push-buttons • Adjustable forks length 800 mm (1150 mm for 800 mm lifting height) • Parking Brake • Polyurethane single roller • Polyamide wheels with polyurethane covering • Safety components • Manual Traction • Battery 12V 80 AH

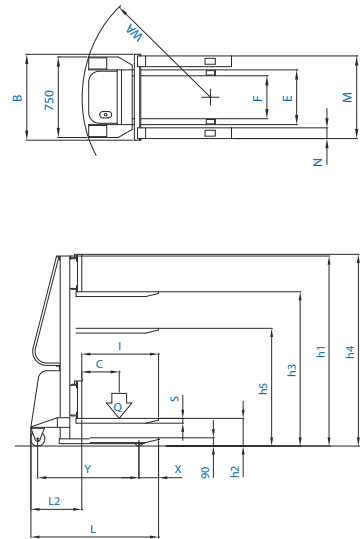

ALFA 12V evo

model		55/25	105/25	55/30	105/30	55/35	105/35
Q	Kg	500	1000	500	1000	500	1000
C	mm	400	400	400	400	400	400
I	mm	800	800	800	800	800	800
L	mm	1390	1410	1390	1410	1390	1410
X	mm	200	200	200	200	200	200
Y	mm	1135	1155	1135	1155	1135	1155
L2	mm	585	605	585	605	585	605
M	mm	240/800	240/800	240/800	240/800	240/800	240/800
N	mm	120	120	120	120	120	120
h1	mm	1750	1750	1990	1990	2250	2250
h2	mm	200	200	200	200	/	/
h3	mm	2500	2500	3000	3000	3500	3500
h4	mm	2920	2920	3420	3420	3920	3920
B	mm	800	800	800	800	800	800
E	mm	525	525	525	525	525	525
F	mm	355	355	355	355	355	355
S	mm	50	55	50	55	50	55
WA	mm	1200	1220	1200	1220	1200	1220

STANDARD EQUIPMENT

- Free lift 200 mm (excluded lifting height mm. 3500) • Built-in electronic battery charger 12V 15A with microprocessor • Forks control by push-buttons • Adjustable forks length 800 mm • Electric end stroke • Parking Brake • Polyurethane single roller • Polyamide wheels with polyurethane covering • Safety components • Manual Traction • Battery 12V 155 AH

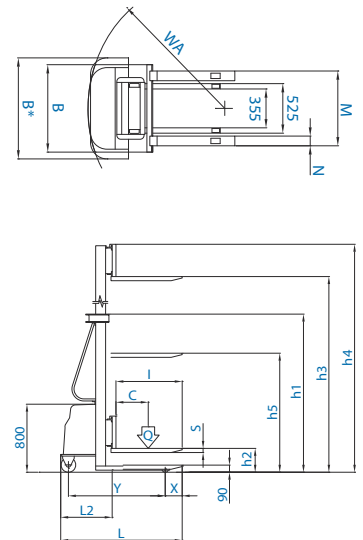

BETA 12V evo | BETA M evo

Stability and Lifting Power

Capacity (kg): 1000 - 1200 - 1500

Lifting Height (mm): 800, 1600, 2500, 3000, 3500

BETA 12V evo

Manual movement, electro-hydraulic lifting with high structural stability to express the maximum lifting power, for maximum lifting power, a solution that is both simple and economical. Single or two-stage mast for lifting up to 3.5 meters.



BETA M evo

Completely manual version to facilitate the easy movement of loads thanks to the handy steering handlebar. Single stage mast for lifting between 800 and 1600 mm.



BETA 12V evo / BETA M evo 08

For lift heights of 800 mm or less, a special short version offers increased visibility, better handling and compact dimensions.

MANUAL & ELECTRIC LIFT STACKERS

Features in detail: _____



FOOT BRAKE + FOOT GUARD:

Pedal parking brake that is installed in the right steering wheel; fixed crushproof foot guard in both wheels.



STEERING ARM:

Handle bar directly controls the 2 rear steering wheels for manual movement of the truck.



ELECTRO-HYDRAULIC LIFTING (BETA 12V evo):

Lifting and lowering control switches are installed in a protective casing. An Emergency Stop switch cuts the power supply.



MANUAL LIFTING (BETA M evo):

Quick lift hand pump with built-in lowering control makes lifting and lowering fast and easy.



BETA 12V evo [800 mm - 1600 mm]

model		105/08	125/08	155/08	105/16	125/16	155/16
Q	Kg	1000	1200	1500	1000	1200	1500
C	mm	600	600	600	600	600	600
I	mm	1150	1150	1150	1150	1150	1150
L	mm	1755	1775	1795	1755	1775	1795
X	mm	380	380	380	380	380	380
X2	mm	235	235	235	235	235	235
Y	mm	1140	1160	1180	1140	1160	1180
L2	mm	600	620	640	600	620	640
M	mm	530	530	530	530	530	530
N	mm	160	160	160	160	160	160
h1	mm	1230	1230	1230	1990	1990	1990
h2	mm	800	800	800	1450	1450	1450
h3	mm	800	800	800	1600	1600	1600
h4	mm	1230	1230	1230	2120	2120	2120
B	mm	755	755	755	755	755	755
WA	mm	1320	1340	1360	1320	1340	1360

STANDARD EQUIPMENT

- High free lift (simplex mast) • Built-in electronic battery charger 12V 15A with microprocessor • Forks control by push-buttons • Fixed forks length mm. 1150 • Electric end stroke • Parking Brake • Polyurethane single roller • Double steering wheels with extra-heavy castors, assembled on bearings • Rubber wheels • Drive steering mounted on bearings • Safety components • Manual Traction • Battery 12V 100AH (for 800/1600 mm lifting height)

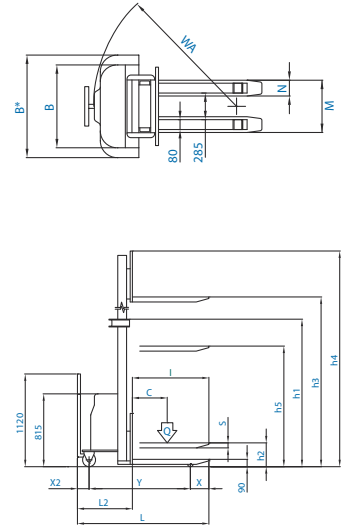

BETA 12V evo [2500 mm - 3000 mm - 3500 mm]

model		105/25	125/25	155/25	105/30	125/30	155/30	105/35	125/35	155/35
Q	Kg	1000	1200	1500	1000	1200	1500	1000	1200	1500
C	mm	600	600	600	600	600	600	600	600	600
I	mm	1150	1150	1150	1150	1150	1150	1150	1150	1150
L	mm	1790	1810	1830	1790	1810	1830	1790	1810	1830
X	mm	415	415	415	415	415	415	415	415	415
X2	mm	235	235	235	235	235	235	235	235	235
Y	mm	1140	1160	1180	1140	1160	1180	1140	1160	1180
L2	mm	640	660	680	640	660	680	640	660	680
M	mm	530	530	530	530	530	530	530	530	530
N	mm	160	160	160	160	160	160	160	160	160
h1	mm	1740	1740	1740	1990	1990	1990	2250	2250	2250
h2	mm	200	200	200	200	200	200	/	/	/
h3	mm	2500	2500	2500	3000	3000	3000	3500	3500	3500
h4	mm	3020	3020	3020	3520	3520	3520	4020	4020	4020
B	mm	755	755	755	755	755	755	1000*	1000*	1000*
WA	mm	1320	1340	1360	1320	1340	1360	1320	1340	1360

STANDARD EQUIPMENT

- Free lift 200 mm (excluded lifting height mm. 3500) • Built-in electronic battery charger 12V 15A with microprocessor • Forks control by push-buttons • Fixed forks length mm. 1150 • Electric end stroke • Parking Brake • Polyurethane single roller • Double steering wheels with extra-heavy castors, assembled on bearings • Rubber wheels - Drive steering mounted on bearings • Safety components • Manual Traction • Battery 12V 155AH

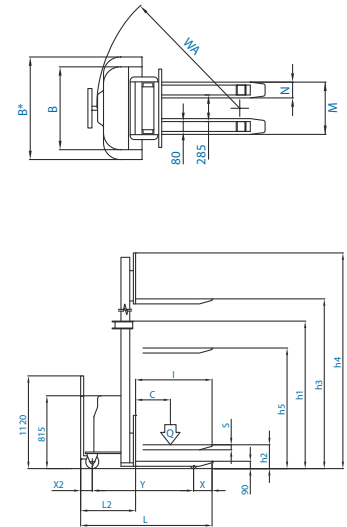

BETA M evo

model		105/08	125/08	105/16	125/16
Q	Kg	1000	1200	1000	1200
C	mm	600	600	600	600
I	mm	1150	1150	1150	1150
L	mm	1755	1755	1755	1755
X	mm	380	380	380	380
X2	mm	235	235	235	235
Y	mm	1140	1160	1140	1160
L2	mm	600	620	600	620
M	mm	530	530	530	530
N	mm	160	160	160	160
h1	mm	1230	1230	1990	1990
h2	mm	800	800	1450	1450
h3	mm	800	800	1600	1600
h4	mm	1230	1230	2120	2120
B	mm	755	755	755	755
WA	mm	1320	1340	1320	1340

STANDARD EQUIPMENT

- High free lift (simplex mast) • Lifting by manual double acting pump • Descent by handwheel • Fixed forks length mm. 1150 • Parking Brake • Polyurethane single roller • Double steering wheels with extra-heavy castors, assembled on bearings • Rubber wheels • Drive steering mounted on bearings • Safety components • Manual Traction

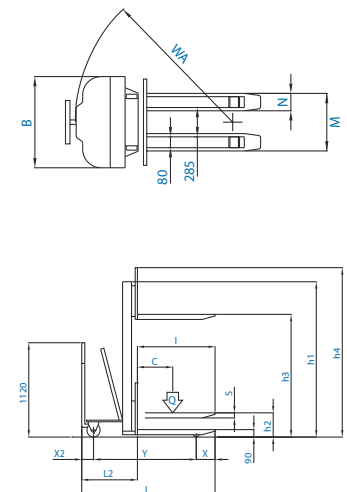

SPEEDY LIGHT / PLUS evo | MASTER LIGHT / PLUS evo

Compact and Agile

Capacity (kg): 1000 - 1200

Lifting Height (mm): 1600, 2500, 2900, 3000, 3300, 3500

MASTER LIGHT evo

Compact, stable, reliable and easy to use, the MASTER LIGHT is the best compromise between power needs and agility for narrow spaces. Nominal capacity of 1000 Kg and maximum lift heights of 2900 mm or 3300 mm.



MASTER PLUS evo

Version with even sturdier structure for capacities up to 1200 Kg and and two-stage mast for lift heights to 3500 mm.

SPEEDY LIGHT / PLUS evo

Simple, fast and economical, the SPEEDY LIGHT offers the best return on investment for any business large or small. Lift heights to 1600 mm and nominal capacities of 1000 or 1200 Kg.

FULLY POWERED
STACKERS

Features in detail: _____



NEW "DR EVO" DRIVE STEERING:
LED battery charge indicator, "turtle" switch for variable speed control and safety reversing (crushproof) switch.



RECHARGING:
A battery charger is built-in to the stacker control housing and includes a 220VAC power cord.



TRACTION AND STABILITY:
Structure with 5 contact points and shock-absorber system for perfect grip by the driving wheel also in case of floor irregularities.



MAINTENANCE:
High frequency 24V microprocessor controls with LED function indicators allow fast and easy troubleshooting.



SPEEDY LIGHT evo / PLUS evo

model		105/16	125/16
Q	Kg	1000	1200
C	mm	600	600
I	mm	1150	1150
L	mm	1780	1780
X	mm	380	380
X2	mm	205	205
Y	mm	1195	1195
L2	mm	630	630
M	mm	530	530
N	mm	160	160
h1	mm	1990	1990
h2	mm	1470	1470
h3	mm	1600	1600
h4	mm	2115	2115
B	mm	800	800
WA	mm	1430	1430

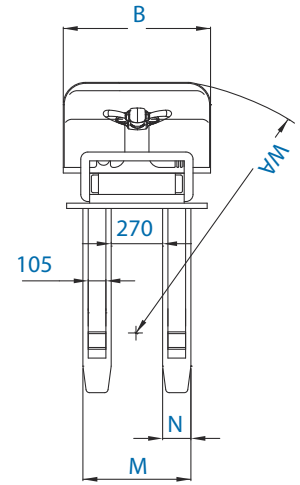
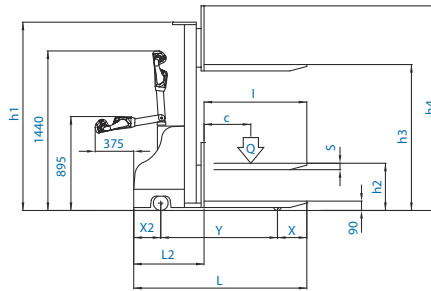

STANDARD EQUIPMENT

- High free lift (simplex mast) • Built-in electronic battery charger 24V 15A with microprocessor • Forks control by push-buttons • Fixed forks length mm. 1150 • Parking Brake • Braking in release contra flow • Shock absorber on driving-wheel • High-frequency electronic plant 24V with microprocessor fault research • Exhausted battery warning-indicator • DR-EVO Steering • Safety components • n.2 Battery 12V 110AH

MASTER LIGHT evo

model		105/29	105/33
Q	Kg	1000	1000
C	mm	600	600
I	mm	1150	1150
L	mm	1820	1820
X	mm	415	415
X2	mm	175	175
Y	mm	1200	1200
L2	mm	670	670
M	mm	530	530
N	mm	160	160
h1	mm	1990	2140
h2	mm	200	-
h3	mm	2900	3300
h4	mm	3420	3820
B	mm	800	800
WA	mm	1420	1420

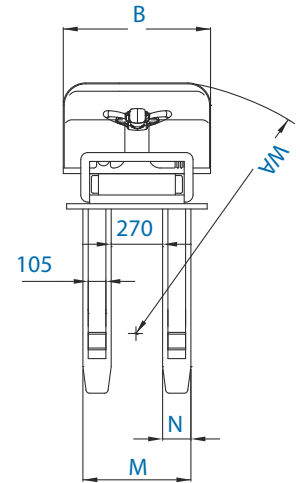
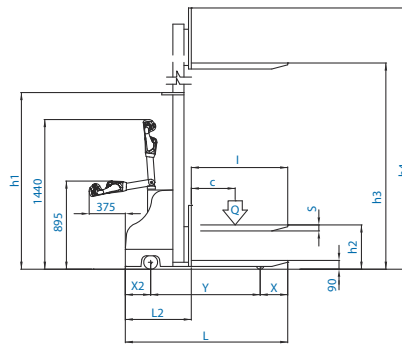

STANDARD EQUIPMENT

- Free lift 200 mm (excluded lifting height mm. 3300) • Built-in electronic battery charger 24V 20A with microprocessor • Forks control by push-buttons • Fixed forks length mm. 1150 • Electric end stroke • Parking Brake • Braking in release contra flow • Shock absorber on driving-wheel • High-frequency electronic plant 24V with microprocessor fault research • Exhausted battery warning-indicator • DR-EVO Steering • Automatic speed reduction • Safety components • n.2 Battery 12V 155AH

MASTER PIÙ evo

model		125/25	125/30	125/35
Q	Kg	1200	1200	1200
C	mm	600	600	600
I	mm	1150	1150	1150
L	mm	1820	1820	1820
X	mm	415	415	415
X2	mm	205	205	205
Y	mm	1200	1200	1200
L2	mm	670	670	670
M	mm	530	530	530
N	mm	160	160	160
h1	mm	1740	1990	2240
h2	mm	200	200	/
h3	mm	2500	3000	3500
h4	mm	3020	3520	4020
B	mm	800	800	1000*
WA	mm	1420	1420	1460

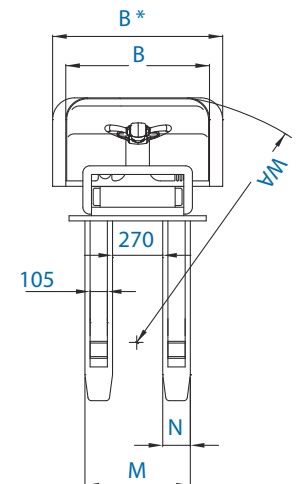
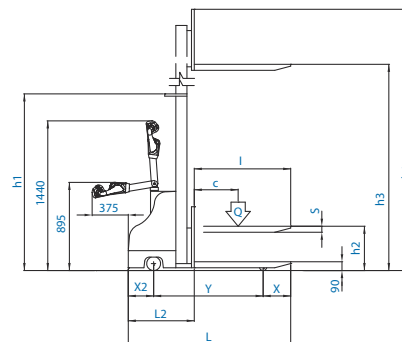



STANDARD EQUIPMENT

- Free lift 200 mm (excluded lifting height mm. 3500) • Built-in electronic battery charger 24V 20A with microprocessor • Forks control by push-buttons • Fixed forks length mm. 1150 • Electric end stroke • Parking Brake • Braking in release contra flow • Shock absorber on driving-wheel • High-frequency electronic plant 24V with microprocessor fault research • Exhausted battery warning-indicator • DR-EVO Steering • Automatic speed reduction • Safety components • n.2 Battery 12V 155AH

DELTA AC-evo / DELTA E AC-evo / DELTA UB AC-evo

Strong and Reliable

 Capacity (kg): 1200 - 1500

 Lifting Height (mm): 1600, 2500, 3000, 3500

DELTA AC-evo

A rugged and reliable stacker for continuous duty pallet handling requirements in medium and large work sites.

AC technology

- + Performance
- + Driving control
- Service Costs



DELTA E AC-evo

Version equipped with extruded-metal mast and special steel sections for heavy-duty operations.

DELTA UB AC-evo

To increase efficiency and reduce operator fatigue in large work sites, the driver-on-board option allows operator stands on a platform while the truck is in motion.



Lateral safety boards for the maximum safety of the operator (Optional)



FULLY POWERED
STACKERS

Features in detail:



NEW "DR EVO" DRIVE STEERING:

Includes LED battery charge indicator, "turtle" switch for variable speed control, precision proportional lifting / lowering control and safety reversing (crushproof) switch.



FREEDOM FROM DOWNTIME:

Powered by 24V industrial batteries with capacities to 270 Ah. A battery charger is built-in to the stacker control housing and includes a 220VAC power cord.



TRACTION AND STABILITY:

Structure with 5 contact points and shock-absorber system for perfect grip by the driving wheel in case of floor irregularities. AC traction drives offer maximum responsiveness in starting and during braking.



MAINTENANCE:

High frequency 24V microprocessor controls with LED function indicators allow fast and easy troubleshooting. Includes PC control software.



DELTA AC-evo

model	125/16	155/16	125/25	155/25	125/30	155/30	125/35	155/35	
Q	Kg	1200	1500	1200	1500	1200	1500	1200	1500
C	mm	600	600	600	600	600	600	600	600
I	mm	1150	1150	1150	1150	1150	1150	1150	1150
L	mm	1895	1915	1930	1950	1930	1950	1930	1950
X	mm	380	380	415	415	415	415	415	415
X2	mm	175	175	175	175	175	175	175	175
Y	mm	1340	1360	1340	1360	1340	1360	1340	1360
L2	mm	745	765	780	800	780	800	780	800
M	mm	530	530	530	530	530	530	530	530
N	mm	160	160	160	160	160	160	160	160
h1	mm	1990	1990	1740	1740	1990	1990	2240	2240
h2	mm	1450	1450	200	200	200	/	/	/
h3	mm	1600	1600	2500	2500	3000	3000	3500	3500
h4	mm	2120	2120	3020	3020	3520	3520	4020	4020
B	mm	840	840	840	840	840	1000*	1000*	1000*
WA	mm	1500	1520	1530	1550	1530	1550	1530	1550

STANDARD EQUIPMENT

- AC three-phase technology traction motors • Electronic plant 24V with controller with mosfet technology complete with inverter and microprocessor fault research • Regenerative braking with consumption reduction and temperature control of the traction motor
- Free lift 200 mm (excluded lifting height mm. 3500) • Built-in electronic battery charger 24V 30A with microprocessor • Forks control by push-buttons • Fixed forks length mm. 1150 • Electric end stroke • Parking Brake • Shock absorber on driving-wheel
- Side wheels with extra-heavy castors • Exhausted battery warning-indicator • DR-EVO Steering • Automatic speed reduction
- Safety components • Traction Battery 24V from 160 to 270 Ah

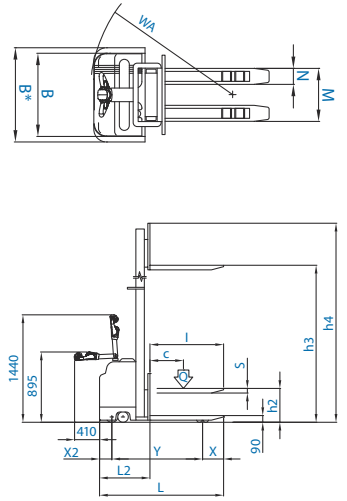

DELTA E AC-evo

model	125/16	155/16	125/25	155/25	125/30	155/30	125/35	155/35	
Q	Kg	1200	1500	1200	1500	1200	1500	1200	1500
C	mm	600	600	600	600	600	600	600	600
I	mm	1150	1150	1150	1150	1150	1150	1150	1150
L	mm	1880	1880	1915	1915	1915	1915	1915	1915
X	mm	375	375	410	410	410	410	410	410
X2	mm	175	175	175	175	175	175	175	175
Y	mm	1330	1330	1330	1330	1330	1330	1330	1330
L2	mm	730	730	765	785	765	785	765	785
M	mm	530	530	530	530	530	530	530	530
N	mm	160	160	160	160	160	160	160	160
h1	mm	1990	1990	1740	1740	1990	1990	2250	2250
h2	mm	1450	1450	200	200	200	/	/	/
h3	mm	1600	1600	2500	2500	3000	3000	3500	3500
h4	mm	2120	2120	3020	3020	3520	3520	4020	4020
B	mm	840	840	840	840	840	1000*	1000*	1000*
WA	mm	1500	1520	1530	1550	1530	1550	1530	1550

STANDARD EQUIPMENT

- AC three-phase technology traction motors • Electronic plant 24V with controller with mosfet technology complete with inverter and microprocessor fault research • Regenerative braking with consumption reduction and temperature control of the traction motor
- Free lift 200 mm (excluded lifting height mm. 3500) • Extruded mast with lateral contrast bearings • Built-in electronic battery charger 24V 30A with microprocessor • Forks control by push-buttons • Fixed forks length mm. 1150 • Electric end stroke • Parking Brake • Shock absorber on driving-wheel • Side wheels with extra-heavy castors • Exhausted battery warning-indicator • DR-EVO Steering • Automatic speed reduction • Safety components • Traction Battery 24V from 160 to 270 Ah

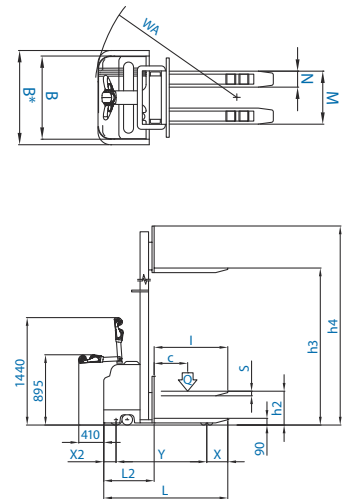

DELTA UB AC-evo

model	125/16	155/16	125/25	155/25	125/30	155/30	125/35	155/35	
Q	Kg	1200	1500	1200	1500	1200	1500	1200	1500
C	mm	600	600	600	600	600	600	600	600
I	mm	1150	1150	1150	1150	1150	1150	1150	1150
L	mm	2000	2020	2035	2055	2035	2055	2035	2055
X	mm	380	380	415	415	415	415	415	415
X2	mm	280	280	280	280	280	280	280	280
Y	mm	1340	1360	1340	1360	1340	1360	1340	1360
L2	mm	850	870	885	905	885	905	885	905
M	mm	530	530	530	530	530	530	530	530
N	mm	160	160	160	160	160	160	160	160
h1	mm	1990	1990	1740	1740	1990	1990	2240	2240
h2	mm	1450	1450	200	200	200	/	/	/
h3	mm	1600	1600	2500	2500	3000	3000	3500	3500
h4	mm	2120	2120	3020	3020	3520	3520	4020	4020
B	mm	840	840	840	840	840	1000*	1000*	1000*
WA*	mm	2020	2040	2050	2070	2050	2070	2050	2070

STANDARD EQUIPMENT

- AC three-phase technology traction motors • Electronic plant 24V with controller with mosfet technology complete with inverter and microprocessor fault research • Regenerative braking with consumption reduction and temperature control of the traction motor
- Free lift 200 mm (excluded lifting height mm. 3500) • Built-in electronic battery charger 24V 30A with microprocessor • Forks control by push-buttons • Fixed forks length mm. 1150 • Electric end stroke • Parking Brake • Shock absorber on driving-wheel • Side wheels with extra-heavy castors • Folding footboard for operator • Exhausted battery warning-indicator • DR-EVO Steering • Automatic speed reduction
- Safety components • Traction Battery 24V from 160 to 270 Ah

[*Platform close]

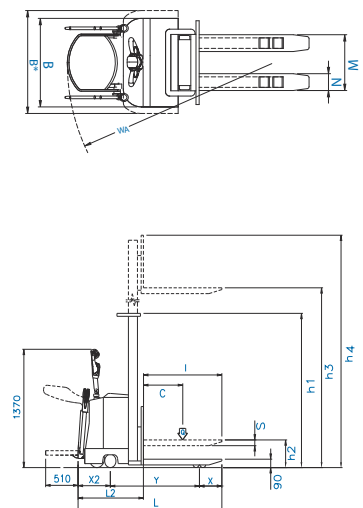

DELTA TP AC-evo

Skids, Ramps and Double-Pallet Handling

Capacity (kg): 1200 - 1500 Lifting Height (mm): 1600, 2500, 3000, 3500

DELTA TP AC-evo

With a built-in leg lift, the DELTA TP is the perfect solution to handle loads in places where you need to pass over ramps, skids, small obstacles and floor irregularities.



Handles two loads simultaneously, one on the forks and the second on the legs.



FIC technology
 + Performance
 + Driving control
 - Service Costs

FULLY POWERED
STACKERS

Feature in details: _____



LEGS LIFTING:

A hydraulic lift adjusts the height of the supporting legs, increasing the clearance between the floor and machine base, enabling the stacker to safely operate on ramps and slopes while simultaneously handling two loads.

4 VIE AC-evo

4 Directions of travel

Capacity (kg): 1200 - 1500 - 2000 Lifting Height (mm): 1600, 2500, 3000, 3500

4 VIE AC-evo

Movement in 4 directions solves the problems associated with handling wide loads such as bars and pipes in confined spaces and narrow aisles.



Lateral movement left or right



Movement forward and reverse

FIC technology
 + Performance
 + Driving control
 - Service Costs



FULLY POWERED
STACKERS

Features in detail: _____



DIRECTION VARIATION:

A hydraulic control rotates the orientation of the wheels by 90° with respect to the forks, thus varying the direction of travel forward and reverse or left and right to handle bulky loads and navigate in confined spaces.



DELTA TP AC-evo

model		125/16	155/16	125/25	155/25	125/30	155/30	125/35	155/35
Q	Kg	1200	1500	1200	1500	1200	1500	1200	1500
C	mm	600	600	600	600	600	600	600	600
I	mm	1150	1150	1150	1150	1150	1150	1150	1150
L	mm	2025	2045	2060	2080	2060	2080	2060	2080
X	mm	275	275	310	310	310	310	310	310
X2	mm	175	175	175	175	175	175	175	175
Y	mm	1575	1595	1575	1595	1575	1595	1575	1595
L2	mm	885	905	920	940	920	940	920	940
M	mm	560	560	560	560	560	560	560	560
N	mm	180	180	180	180	180	180	180	180
h1	mm	1990	1990	1740	1740	1990	1990	2250	2250
h2	mm	1450	1450	200	200	200	200	/	/
h3	mm	1600	1600	2500	2500	3000	3000	3500	3500
h4	mm	2120	2120	3020	3020	3520	3520	4020	4020
B	mm	840	840	840	840	840	840	1000	1000
WA	mm	1770	1790	1770	1790	1770	1790	1770	1790

STANDARD EQUIPMENT

- AC three-phase technology traction motors • Electronic plant 24V with controller with mosfet technology complete with inverter and microprocessor fault research • Regenerative braking with consumption reduction and temperature control of the traction motor • Free lift 200 mm (excluded lifting height mm 3500) • Built-in electronic battery charger 24V 30A with microprocessor • Forks control by hydraulic distributor • Support legs lift by hydraulic distributor • Fixed forks length mm 1150 • Electric end stroke • Parking Brake • Shock absorber on driving-wheel • Side wheels with extra-heavy castors • Exhausted battery warning-indicator • DR-EVO Steering • Automatic speed reduction • Safety components • Traction Battery 24V from 160 to 270 Ah

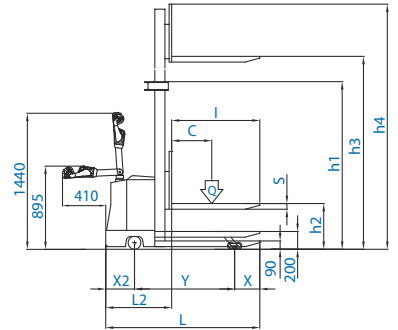
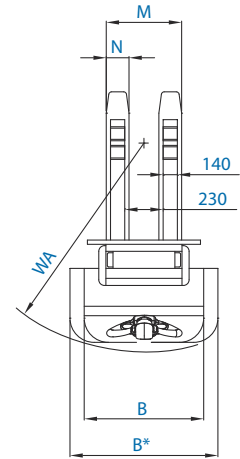

4 VIE AC-evo

model		125/16	155/16	200/16	125/25	155/25	200/25	125/30	155/30	200/30	125/35	155/35	200/35
Q	Kg	1200	1500	2000	1200	1500	2000	1200	1500	2000	1200	1500	2000
C	mm	450	450	600	450	450	600	450	450	600	450	450	600
I	mm	950	950	1150	950	950	1150	950	950	1150	950	950	1150
L	mm	1780	1780	1805	1810	1810	1835	1810	1810	1835	1810	1810	1835
X	mm	310	310	310	330	330	330	330	330	330	330	330	330
X2	mm	175	175	175	175	175	175	175	175	175	175	175	175
Y	mm	1285	1285	1285	1305	1305	1305	1305	1305	1305	1305	1305	1305
L2	mm	840	840	865	860	860	885	860	860	885	860	860	885
M	mm	350/1300	350/1300	350/1300	350/1300	350/1300	350/1300	350/1300	350/1300	350/1300	350/1300	350/1300	350/1300
N	mm	160	160	160	160	160	160	160	160	160	160	160	160
h1	mm	1990	1990	1990	1740	1740	1740	1990	1990	1990	2250	2250	2250
h2	mm	1450	1450	1450	200	200	200	200	200	200	/	/	-
h3	mm	1600	1600	1600	2500	2500	2500	3000	3000	3000	3500	3500	3500
h4	mm	2070	2070	2070	2970	2970	2970	3470	3470	3470	3970	3970	3970
B	mm	1620	1620	1620	1620	1620	1620	1620	1620	1620	1620	1620	1620
WA	mm	1510	1510	1510	1510	1510	1510	1510	1510	1510	1510	1510	1510

STANDARD EQUIPMENT

- AC three-phase technology traction motors • Electronic plant 24V with controller with mosfet technology complete with inverter and microprocessor fault research • Regenerative braking with consumption reduction and temperature control of the traction motor • Free lift 200 mm (excluded lifting height mm. 3500) • Extruded mast with lateral contrast bearings • Built-in electronic battery charger 24V 30A with microprocessor • Forks control by hydraulic distributor • Hydraulic directional front-wheel • Adjustable forks length mm 950 • Electric end stroke • Parking Brake • Shock absorber on driving-wheel • Side wheels with extra-heavy castors • Exhausted battery warning-indicator • DR-EVO Steering • Automatic speed reduction • Safety components • Traction Battery 24V from 160 to 270 Ah

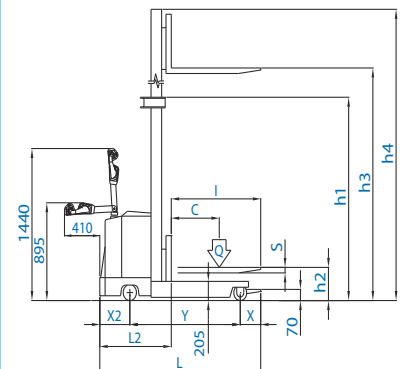
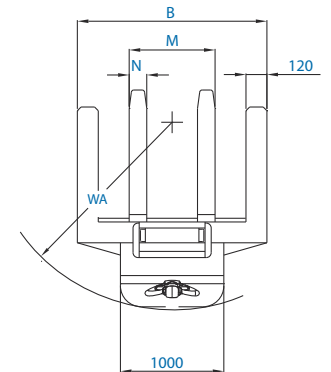

DELTA CP AC-evo

The "Forklift Truck" Alternative

Capacity (kg): 600 - 800 - 1000 - 1200 - 1500 Lifting Height (mm): 1600, 2500, 3000, 3500

DELTA CP AC-evo

Easy to use and highly maneuverable with a compact, economical design, the DELTA CP offers all of the advantages of expensive driver-on-board forklifts.



Tilting Mast

A hydraulically powered tilting mast maintains the balance and position of the load in all handling situations.



No front legs

With no front legs, the DELTA CP can completely fork the pallet and clear any obstacles on the floor.



COUNTERBALANCED TRUCKS

Feature in details: _____



DRIVING AND TRACTION:

Thanks to power assisted steering (standard on all trucks except 600 kg capacity) the DELTA CP is agile in tight spaces where maneuvering is difficult. AC traction drives offer maximum responsiveness in starting and during braking.



ADJUSTABLE CANTILEVER FORKS:

High strength forged metal forks can be adjusted manually with the FEM fork holder plate to handle non-standard size pallet and containers.



FREEDOM FROM DOWNTIME:

Powered by 24V industrial batteries with capacities to 270 Ah, the DELTA CP offers extended use time between battery charges.



THE "FORKLIFT TRUCK" ALTERNATIVE:

The DELTA CP can be used by any operator with minimal training, without the need for a driver's license required for traditional driver.



DELTA CP AC-evo [1600 mm - 2500 mm]

model		60/16	80/16	100/16	120/16	150/16	60/25	80/25	100/25	120/25	150/25
Q	Kg	600	800	1000	1200	1500	600	800	1000	1200	1500
C	mm	600	600	600	600	600	600	600	600	600	600
l	mm	1200	1200	1200	1200	1200	1200	1200	1200	1200	1200
L	mm	2480	2480	2650	2730	2835	2480	2480	2650	2730	2835
X	mm	175	175	185	185	185	175	175	185	185	185
X2	mm	325	325	325	325	325	325	325	325	325	325
Y	mm	780	780	940	1070	1135	780	780	940	1070	1135
L2	mm	1280	1280	1450	1580	1635	1280	1280	1450	1580	1635
M	mm	775	775	775	775	775	775	775	775	775	775
N	mm	80	100	100	100	100	80	100	100	100	100
h1	mm	1990	1990	1990	1990	1990	1740	1740	1740	1740	1740
h2	mm	1450	1450	1450	1450	1450	200	200	200	200	200
h3	mm	1550	1550	1550	1550	1550	2450	2450	2450	2450	2450
h4	mm	2100	2100	2100	2100	2100	3020	3020	3020	3020	3020
B	mm	855	855	855	855	855	855	855	855	855	855
WA	mm	1150	1150	1360	1435	1505	1150	1150	1360	1435	1505

STANDARD EQUIPMENT

- Free lift 200 mm • AC three-phase technology traction motors • Electronic plant 24V with controller with mosfet technology complete with inverter and microprocessor fault research • Regenerative braking with consumption reduction and temperature control of the traction motor • High frequency electronic battery charger 24V 40A • Forks control by hydraulic distributor • Hydraulic tilting of the mast • Forged forks length mm. 1150 • Electric end stroke • Parking Brake • Side wheels with extra-heavy castors • Extruded mast with lateral contrast bearings • Exhausted battery warning-indicator • DR-EVO Steering • Safety components • Automatic speed reduction • Power assisted steering included (except for capacity 600 kgs.) • Traction Battery 24V 270 Ah

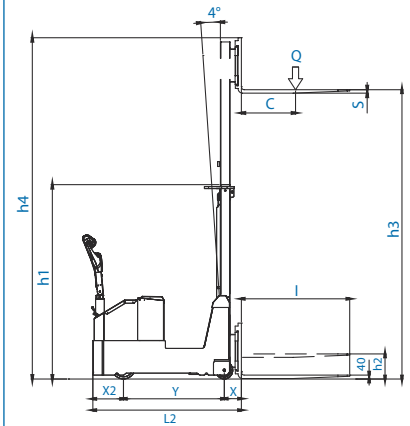
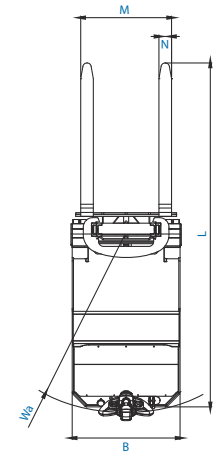

DELTA CP AC-evo [3000 mm - 3500 mm]

model		60/30	80/30	100/30	120/30	150/30	60/35	80/35	100/35	120/35	150/35
Q	Kg	600	800	1000	1200	1500	600	800	1000	1200	1500
C	mm	600	600	600	600	600	600	600	600	600	600
l	mm	1200	1200	1200	1200	1200	1200	1200	1200	1200	1200
L	mm	2480	2480	2650	2730	2835	2480	2480	2650	2730	2835
X	mm	175	175	185	185	185	175	175	185	185	185
X2	mm	325	325	325	325	325	325	325	325	325	325
Y	mm	780	780	940	1070	1135	780	780	940	1070	1135
L2	mm	1280	1280	1450	1580	1635	1280	1280	1450	1580	1635
M	mm	775	775	775	775	775	775	775	775	775	775
N	mm	80	100	100	100	100	80	100	100	100	100
h1	mm	1990	1990	1990	1990	1990	2240	2240	2240	2240	2240
h2	mm	200	200	200	200	200	/	/	/	/	/
h3	mm	2950	2950	2950	2950	2950	3450	3450	3450	3450	3450
h4	mm	3500	3500	3500	3500	3500	4020	4020	4020	4020	4020
B	mm	855	855	855	855	855	1100	1100	1100	1100	1100
WA	mm	1150	1150	1360	1435	1505	1150	1150	1360	1435	1505

STANDARD EQUIPMENT

- Free lift 200 mm (excluded lifting height mm. 3500) • AC three-phase technology traction motors • Electronic plant 24V with controller with mosfet technology complete with inverter and microprocessor fault research • Regenerative braking with consumption reduction and temperature control of the traction motor • High frequency electronic battery charger 24V 40A • Forks control by hydraulic distributor • Hydraulic tilting of the mast • Forged forks length mm. 1150 • Electric end stroke • Parking Brake • Side wheels with extra-heavy castors • Extruded mast with lateral contrast bearings • Exhausted battery warning-indicator • DR-EVO Steering • Safety components • Automatic speed reduction • Power assisted steering included (except for capacity 600 kgs.) • Traction Battery 24V 270 Ah

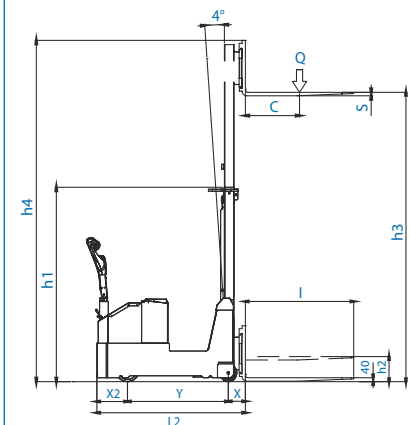
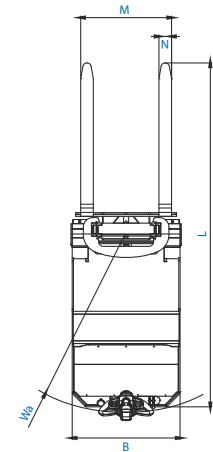

DELTA TRX AC-evo | DELTA TRXFL AC-evo

Safety at maximum heights

Capacity (kg): 1400 Lifting Height (mm): 3500, 4000, 4500

DELTA TRXFL AC-evo

A three-stage lifting mast with high strength steel sections and an enlarged structure enables the DELTA TRXFL to reach picking and storage heights up to 4.5 meters with complete safety.



Full free lift:

A three piston lift system allows a full free lift of the forks without increasing the overall height of the truck's lift column. The center piston raises the forks before the two side pistons raise the mast.



AC technology

- + Performance
- + Driving control
- Service Costs



Full Visibility:

The two lifting pistons are installed on the side to give the operator full visibility in front of the truck during handling and storing operations.

DELTA TRX AC-evo

Version with load lifting system that includes two side pistons and no central piston offers full visibility in front of the truck.

FULLY POWERED STACKERS

Feature in details: _____



MAXIMUM ELEVATION, MINIMUM OVERALL DIMENSIONS:

The three-stage lifting mast allows reaching considerable elevation heights and, at the same time, assures minimum overall dimensions with lowered forks.



NEW "DR EVO" DRIVE STEERING:

Includes LED battery charge indicator, "turtle" switch for variable speed control, precision proportional lifting / lowering control and safety reversing (crushproof) switch.



FREEDOM FROM DOWNTIME:

Powered by 24V industrial batteries with capacities to 270 Ah. A battery charger is built-in to the stacker control housing and includes a 220VAC power cord.



TRACTION AND STABILITY:

Structure with 5 contact points and shock-absorber system for perfect grip by the driving wheel in case of floor irregularities. AC traction drives offer maximum responsiveness in starting and during braking.



DELTA TRXFL AC-evo

model		145/35	145/40	145/45
Q	Kg	1400	1400	1400
C	mm	600	600	600
I	mm	1150	1150	1150
L	mm	1970	1970	1970
X	mm	375	375	375
X2	mm	175	175	175
Y	mm	1415	1415	1415
L2	mm	820	820	820
M	mm	550	550	550
N	mm	180	180	180
h1	mm	1745	1910	2075
h2	mm	1225	1390	1555
h3	mm	3500	4000	4500
h4	mm	4020	4520	5020
B	mm	1000	1000	1000
WA	mm	1630	1630	1630

STANDARD EQUIPMENT

• AC three-phase technology traction motors • Electronic plant 24V with controller with mosfet technology complete with inverter and microprocessor fault research • Regenerative braking with consumption reduction and temperature control of the traction motor • Free lift (1225 – 1390 – 1555 mm) • High frequency electronic battery charger 24V 40A • Forks control by push-buttons • Fixed forks length mm. 1150 • Electric end stroke • Parking Brake • Shock absorber on driving-wheel • Side wheels with extra-heavy castors • Extruded triplex mast with lateral contrast bearings • Double lateral chromed pistons • Exhausted battery warning-indicator • DR-EVO Steering • Automatic speed reduction • Safety components • Traction Battery 24V 240/270 Ah

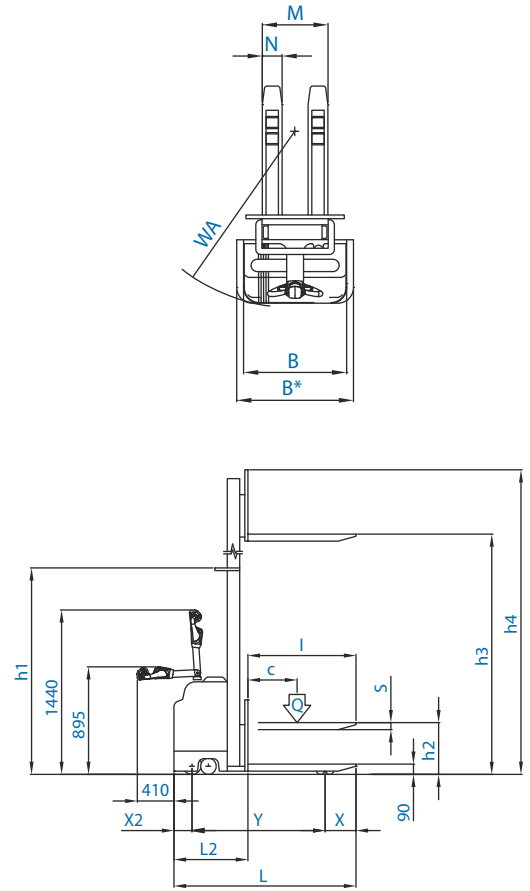

DELTA TRX AC-evo

model		145/35	145/40	145/45
Q	Kg	1400	1400	1400
C	mm	600	600	600
I	mm	1150	1150	1150
L	mm	1970	1970	1970
X	mm	375	375	375
X2	mm	175	175	175
Y	mm	1415	1415	1415
L2	mm	820	820	820
M	mm	550	550	550
N	mm	180	180	180
h1	mm	1745	1910	2075
h2	mm	/	/	/
h3	mm	3500	4000	4500
h4	mm	4020	4520	5020
B	mm	1000	1000	1000
WA	mm	1630	1630	1630

STANDARD EQUIPMENT

• AC three-phase technology traction motors • Electronic plant 24V with controller with mosfet technology complete with inverter and microprocessor fault research • Regenerative braking with consumption reduction and temperature control of the traction motor • High frequency electronic battery charger 24V 40A • Forks control by push-buttons • Fixed forks length mm. 1150 • Electric end stroke • Parking Brake • Shock absorber on driving-wheel • Side wheels with extra-heavy castors • Extruded triplex mast with lateral contrast bearings • Double lateral chromed pistons • Exhausted battery warning-indicator • DR-EVO Steering • Automatic speed reduction • Safety components • Traction Battery 24V 240/270 Ah

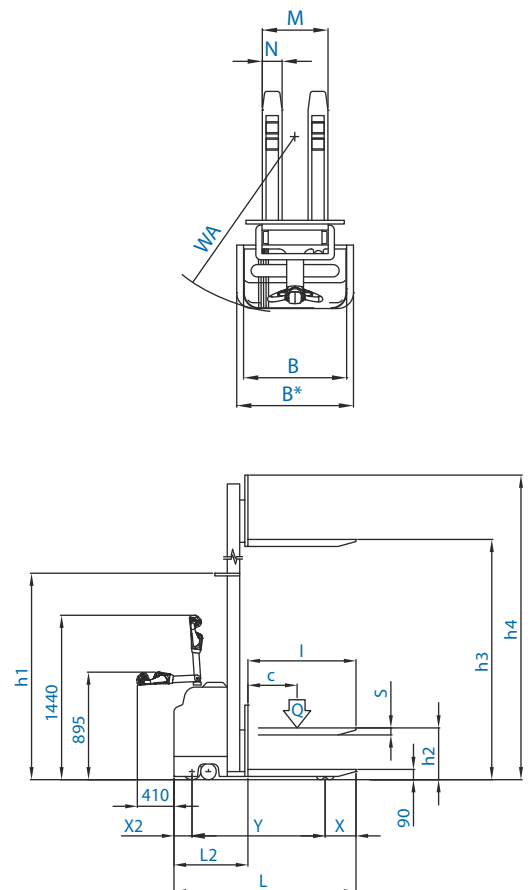

MAX AC-evo

Maximum Power for maximum performance

Capacity (kg): 1300 - 1600 - 2000 Lifting Height (mm): 1600, 2500, 3000, 3500

MAX AC-evo

Designed for maximum performance and safety for extreme loads in the most demanding applications, the MAX has extra heavy-duty masts, forks, frames and legs. Load capacities to 2000 kg and lift heights to 3.5 meters.



Masts made with extruded metal

Masts with heavy-duty special steel sections offer strength and stability in the most demanding applications.

AC technology

- + Performance
- + Driving control
- Service Costs

FULLY POWERED STACKERS

Feature in details: _____



DOUBLE SIDE PISTON:

Maximum performance, stability and safety result from two powerful side-mounted pistons.



NEW "DR EVO" DRIVE STEERING:

Includes LED battery charge indicator, "turtle" switch for variable speed control, precision proportional lifting / lowering control and safety reversing (crushproof) switch.



FREEDOM FROM DOWNTIME:

Powered by 24V industrial batteries with capacities to 270 Ah. A battery charger is built-in to the stacker control housing and includes a 220VAC power cord.



TRACTION AND STABILITY:

Structure with 5 contact points and shock-absorber system for perfect grip by the driving wheel in case of floor irregularities. AC traction drives offer maximum responsiveness in starting and during braking.



Full Visibility

The two lifting pistons are installed on the side to give the operator full visibility in front of the truck during handling and storing operations.



MAX AC-evo [1600 mm - 2500 mm]

model		130/16	160/16	200/16	130/25	160/25	200/25
Q	Kg	1300	1600	2000	1300	1600	2000
C	mm	600	600	600	600	600	600
I	mm	1150	1150	1150	1150	1150	1150
L	mm	1920	1920	1940	1940	1940	1960
X	mm	380	380	380	380	380	380
X2	mm	175	175	175	175	175	175
Y	mm	1365	1365	1385	1385	1385	1405
L2	mm	760	760	780	780	780	800
M	mm	530	530	550	530	530	550
N	mm	160	160	180	160	160	180
h1	mm	1990	1990	1990	1740	1740	1740
h2	mm	1450	1450	1450	200	200	200
h3	mm	1600	1600	1600	2500	2500	2500
h4	mm	2120	2120	2120	3020	3020	3020
B	mm	840	840	1000	840	840	1000
WA	mm	1550	1550	1550	1570	1570	1570

STANDARD EQUIPMENT

- AC three-phase technology traction motors • Electronic plant 24V with controller with mosfet technology complete with inverter and microprocessor fault research • Regenerative braking with consumption reduction and temperature control of the traction motor • Free lift 200 mm • Built-in electronic battery charger 24V 30A with microprocessor • Forks control by push-buttons • Fixed forks length mm. 1150 • Electric end stroke • Parking Brake • Shock absorber on driving-wheel • Side wheels with extra-heavy castors • High visibility extruded mast with lateral contrast bearings • Double lateral chromed pistons • Exhausted battery warning-indicator • DR-EVO Steering • Automatic speed reduction • Safety components • Traction Battery 24V from 160 to 270 Ah

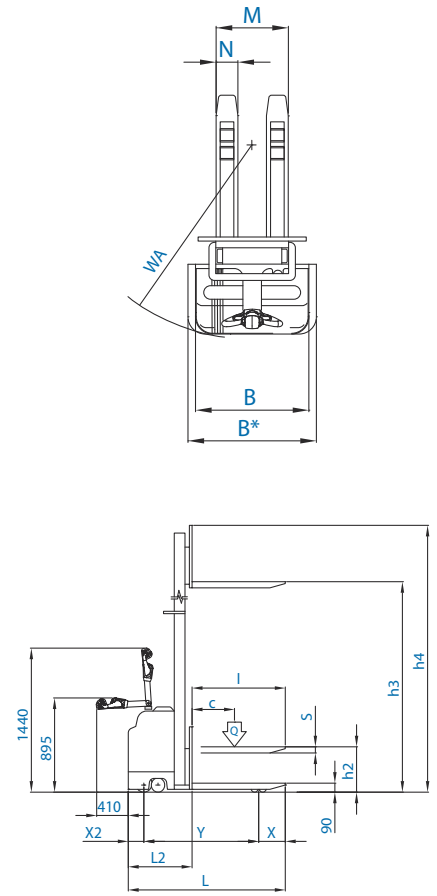

MAX AC-evo [3000 mm - 3500 mm]

model		130/30	160/30	200/30	130/35	160/35	200/35
Q	Kg	1300	1600	2000	1300	1600	2000
C	mm	600	600	600	600	600	600
I	mm	1150	1150	1150	1150	1150	1150
L	mm	1940	1940	1960	1940	1940	1960
X	mm	380	380	380	380	380	380
X2	mm	175	175	175	175	175	175
Y	mm	1385	1385	1405	1385	1385	1405
L2	mm	780	780	800	780	780	800
M	mm	530	530	550	530	530	550
N	mm	160	160	180	160	160	180
h1	mm	1990	1990	1990	2240	2240	2240
h2	mm	200	200	200	/	/	/
h3	mm	3000	3000	3000	3500	3500	3500
h4	mm	3520	3520	3520	4020	4020	4020
B	mm	840	840	1000	1000	1000	1000
WA	mm	1570	1570	1570	1570	1570	1570

STANDARD EQUIPMENT

- AC three-phase technology traction motors • Electronic plant 24V with controller with mosfet technology complete with inverter and microprocessor fault research • Regenerative braking with consumption reduction and temperature control of the traction motor • Free lift 200 mm (excluded lifting height mm. 3500) • Built-in electronic battery charger 24V 30A with microprocessor • Forks control by push-buttons • Fixed forks length mm. 1150 • Electric end stroke • Parking Brake • Shock absorber on driving-wheel • Side wheels with extra-heavy castors • High visibility extruded mast with lateral contrast bearings • Double lateral chromed pistons • Exhausted battery warning-indicator • DR-EVO Steering • Automatic speed reduction • Safety components • Traction Battery 24V from 160 to 270 Ah

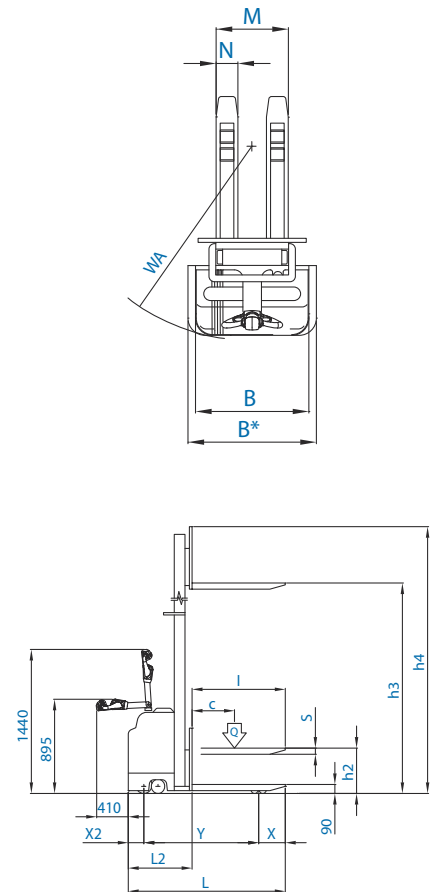

ALFA MGF evo | ALFA MGL evo

Drum, Barrel and Tank Handling

Capacity (kg): 300 (more capacity on demand) | Lifting Height (mm): 1880/1660 (higher lifting on demand)

ALFA MGF evo

The ideal solution to safely lift, transport, fill and empty drums and cylindrical containers. A mechanical clamp secures drums of varying diameters, and a hand operated turner precisely controls the forward rotation.



ALFA MGL evo

Version with hand operated turner that rotates and empties the drum to the side of the truck.

ATTACHEMENTS FOR SPECIAL APPLICATIONS

Features in detail: _____



MANUAL CLOSING:

A hand wheel closes the manual clamp and adjusts for different drum diameters.



MANUAL REDUCTION GEAR:

Hand operated mechanical rotator with reduction gears allows turning the drum with very little effort.

ALFA MRF evo | ALFA MRL evo

Tilting of industrial containers and cases

Capacity (kg): 400 | Lifting Height (mm): N.D.

ALFA MRF evo FRONTAL TILTER

The tilting forks make the picking of parts from containers safe and easy.

A hand operated pump tilts the load up to 85° to reach the bottom of the container.



ALFA MRL evo LATERAL TILTER

Side load tilting option with +/- 20° tilting angle.

ATTACHEMENTS FOR SPECIAL APPLICATIONS

Features in detail: _____



CUSTOM SOLUTIONS:

Armani will customize the width and length of the forks to perfectly suit non-standard containers.



MANUAL OPERATION:

A safe and easy to use hand hydraulic pump powers the lifting or tilting function.



ALFA MGF evo

model	MGF
Q	Kg 300
C	mm 685
I	mm /
L	mm 1550
X	mm 405
Y	mm 1100
L2	mm 585
E	mm 650
F	mm 750
h1	mm 1990
h2	mm 1880
h3	mm 1880
h4	mm 2000
B	mm 800
WA	mm 1190

STANDARD EQUIPMENT

- Manual drum tipper with reducer (300 kgs capacity)
- Lifting by fast manual pump (without load)
- Descent by lever
- 360° frontal drum rotation
- Parking brake
- Polyurethane single roller
- Polyamide wheels with polyurethane covering
- Safety components
- Manual traction

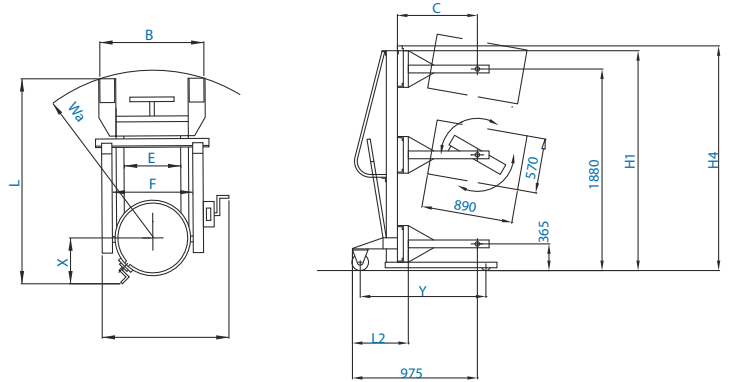

ALFA MGL evo

model	MGL
Q	Kg 300
C	mm 370
I	mm /
L	mm 1465
X	mm 280
Y	mm 1115
L2	mm 585
E	mm 650
F	mm 750
h1	mm 1990
h2	mm 1330
h3	mm 1660
h4	mm 2300
B	mm 800
WA	mm 1190

STANDARD EQUIPMENT

- Manual drum tipper with reducer (300 kgs capacity)
- Lifting by fast manual pump (without load)
- Descent by lever
- 360° lateral drum rotation
- Parking brake
- Polyurethane single roller
- Polyamide wheels with polyurethane covering
- Safety components
- Manual traction

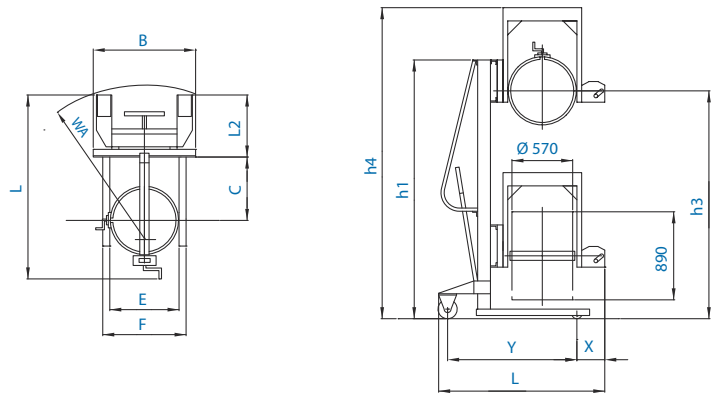

ALFA MRF evo

FRONTAL FILTER

model	FRONTAL
Q	Kg 1000
C	mm 400
I	mm 800
L	mm 1315
X	mm 50
Y	mm 1195
L2	mm 515
M	mm 560
N	mm 120
h1	mm 1120
h2	mm 900
h3	mm 900
h4	mm 1645
B	mm 735
F	mm 355
S	mm 55
WA	mm 1320

STANDARD EQUIPMENT

- Rated capacity 1000 Kgs
- Lifting by manual double acting pump
- Descent by lever
- Fixed forks length mm. 800
- 85° max. tilting frontal angle
- Parking brake
- Polyurethane single roller
- Polyamide wheels with polyurethane covering
- Safety components
- Manual traction

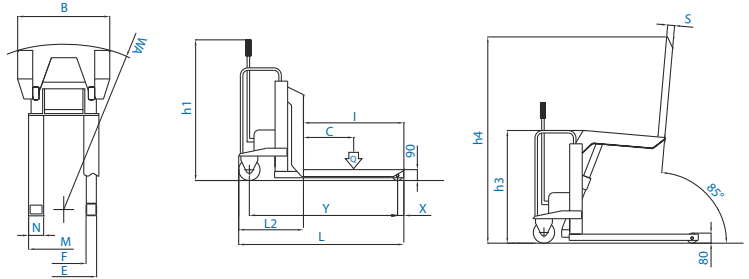

ALFA MRL evo

LATERAL FILTER

model	LATERAL
Qf	Kg 1000
Qr	Kg 400
C	mm 450
I	mm 900
L	mm 1420
X	mm 176
Y	mm 1140
L2	mm 520
M	mm 445
N	mm 30
h1	mm 1230
h2	mm 800
B	mm 755
E	Kg 724
F	mm 540
S	mm 70
WA	mm 1265
â	mm 20°

STANDARD EQUIPMENT

- Rated capacity 1000 Kgs (Qf)
- Side tilter capacity 400 Kgs (Qr)
- Lifting by fast manual pump (without load)
- Descent by lever
- Fixed forks length mm. 900
- Tilting angle from -20° to +20°
- Parking brake
- Polyurethane single roller
- Polyamide wheels with polyurethane covering
- Safety components
- Manual traction

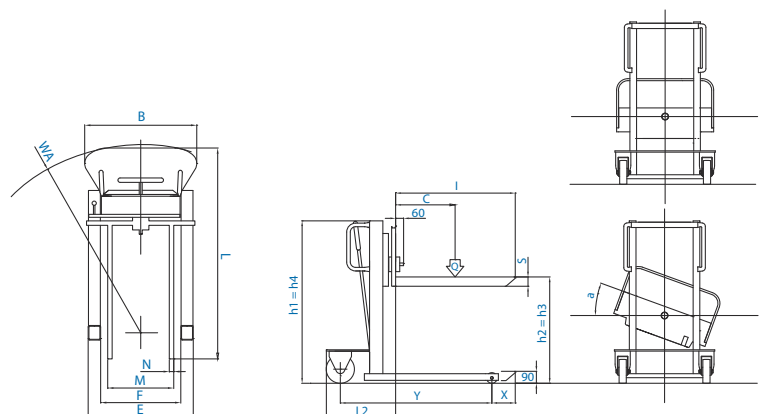

TPM | TPM PE | TPM INOX

The ideal "fellow worker"

Capacity (kg): 2000 - 2500 - 3000 | Lifting Height (mm): 200

TPM

The ideal assistant for simple and quick handling of palletized goods in confined spaces. The rigid frame, reliable hydraulic pump made from aluminum, and wheels with easy rolling bearings assure agility and stability.



Additional rollers make inserting and removal from the pallet nearly effortless.



3-position (lowering - neutral - lifting) control lever in the steering arm.



TPM INOX

A fully stainless steel version can be used in environments with high humidity, dust and corrosive chemicals.



TPM PE

An optional load cell based weighing system installed in the forks has a digital display to save the operator time and effort.



HAND PALLET TRUCKS

Features in detail:

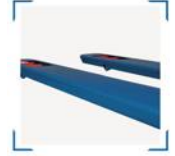

REDUCED FORKS:
Forks reduced to only 51mm thickness for special pallets that are characterised by a reduced forking gap.



LONGER FORKS:
Longer forks up to 1500 mm, 1800 mm and 2000 mm; shorter forks to 800 mm and 1000 mm.



SHAPED FORKS:
Custom forks are available for handling rolls and coils with various diameters.

TPM 10 GAL 12V | TPM 10 GAL

Stacker Pallet Truck

Capacity (kg): 1000 | Lifting Height (mm): 800

TPM 10 GAL 12V

A full lift pallet truck with 12V battery powered electric lift, the TPM is a versatile handling solution. The scissor lift mechanism raises the load to 800 mm from the floor. The TPM GAL is simple, stable and ergonomic. Use it as a work bench or to support assembly lines.



TPM 10 GAL

A simpler, more economical version of the TPM GAL with hand operated hydraulic lift.



HAND PALLET TRUCKS

Features in detail:



BUTTONS:
Push buttons for lifting and lowering are built into the steering arm.



STABILIZERS:
Foot guard and rear stabilizers to assure maximum stability.



BATTERY CHARGER:
12V, 15A battery charger built-in into the machine frame.



TPM

model		TPM 2500	TPM 3000	TPM FRUTTA
Q	Kg	2500	3000	2500
C	mm	600	600	600
I	mm	1150	1150	1150
L	mm	1545	1545	1545
L2	mm	395	395	395
M	mm	540	540	685
N	mm	160	160	160
Ø	mm	200	200	200

model		TPM 2000/1500	TPM 2000/1800	TPM 2000/2000
Q	Kg	2000	2000	2000
C	mm	750	900	1000
I	mm	1500	1800	2000
L	mm	1895	2195	2395
L2	mm	395	395	395
M	mm	540	540	540
N	mm	160	160	160
Ø	mm	200	200	200

§ STANDARD EQUIPMENT

- Strong steel frame • Steel lifting pump • Steel lever system • Entering rollers
- Lifting by manual pump • Steering lever with 3 positions • Manual traction

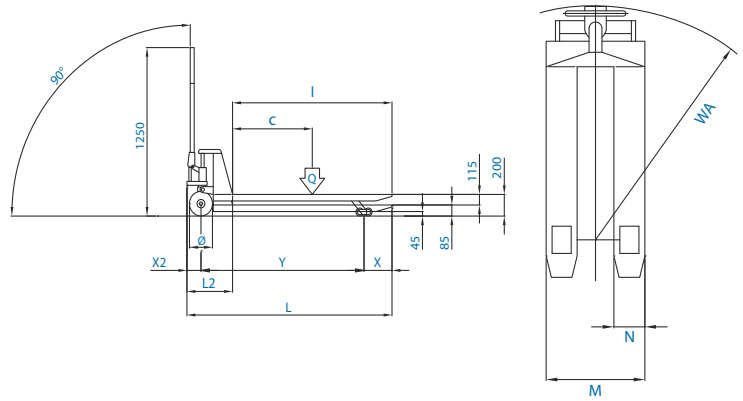

TPM 10 GAL

model		TPM 10 GAL
Q	Kg	1000
C	mm	600
I	mm	1150
L	mm	1545
X	mm	215
X2	mm	135
Y	mm	1195
L2	mm	395
M	mm	520
N	mm	180
Ø	mm	150
h1	mm	85
h3	mm	800

§ STANDARD EQUIPMENT

- Manual traction • Steel lifting pump • Lifting by manual pump
- Steering lever with 3 positions • Forks lifting mm. 800

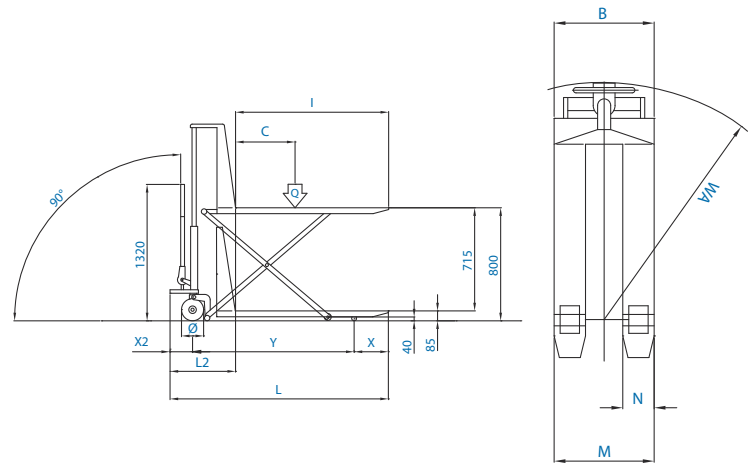

TPM 10 GAL 12V

model		TPM 10 GAL 12V
Q	Kg	1000
C	mm	600
I	mm	1150
L	mm	1640
X	mm	180
X2	mm	145
Y	mm	1315
L2	mm	490
M	mm	520
N	mm	160
Ø	mm	160
h1	mm	85
h3	mm	800

§ STANDARD EQUIPMENT

- Manual traction • 12V Electric lifting • Battery 12V 110AH (12V 155 Ah on request)
- Built-in electronic battery charger 24V 15A with microprocessor • Forks lifting mm. 800 • Emergency stop button • Exhausted battery warning-indicator • Forks control by push-buttons • Electric end stroke • Anti-crushing safety micro by steering • Foot protection on rear wheel

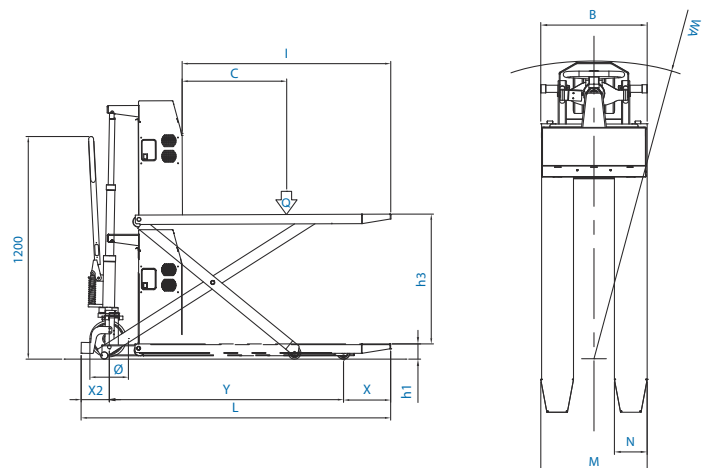

SMART LIGHT evo | SMART PLUS AC-evo

Compactness for the smallest spaces

Capacity (kg): 1500 / 2000 Lifting Height (mm): 200

SMART LIGHT evo / SMART PLUS AC-evo

Maximum compactness, versatility and elegance for agile, quick and safe handling operations.

The smallest device within its category, compact as a manual pallet truck, it is the best solution to get out of small spaces, where agility and compactness are the fundamental features being required.

The aforesaid features make it particularly suitable for handling operations on lorries and articulated lorries, which are characterised by very small manoeuvring spaces.

It is available in 1500 Kg (Smart Light) and 2000 Kg (Smart Plus) versions.



FC technology

- + Performance
- + Driving control
- Service Costs

POWERED PALLET TRUCKS

Features in detail:



NEW DR EVO DRIVE STEERING:

Includes LED battery charge indicator, "turtle" switch for variable speed control, precision proportional lifting / lowering control and safety reversing (crushproof) switch.



TRACTION AND STABILITY:

Structure with 5 contact points and shock-absorber system for perfect grip by the driving wheel in case of floor irregularities. AC traction drives (only for SMART PLUS) offer maximum responsiveness in starting and during braking.

SMART DL AC-evo

Multi-functionality

Capacity (kg): 1800-1050 / 1800-700 Lifting Height (mm): 200-1400 / 200-700

SMART DL AC-evo 180/14

In addition to lifting to 200 mm from the floor like a common pallet truck, the SMART DL's forks lift independently to 1400 mm. Combine traditional pallet handling operations with additional functions such as storage and picking from shelves and unloading motor vehicles. The lifting of the support legs allows simultaneous handling of two pallets and passing over ramps and other obstacles on the floor.

FC technology

- + Performance
- + Driving control
- Service Costs



SMART DL AC-evo 180/07

Version equipped with first lifting stage up to 200 mm and secondary fork lifting up to 700 mm.

POWERED PALLET TRUCKS

Features in detail:



Handling of two pallets.



Motor Vehicle Loading and Unloading Operations.



Storage and picking of goods.





SMART LIGHT evo - SMART PLUS AC-evo

model		150/200	200/200
Q	Kg	1500	2000
C	mm	600	600
I	mm	1150 - 1000 - 800	1150 - 1000 - 800
L	mm	1615	1615
X	mm	205	205
X2	mm	190	190
Y	mm	1220	1220
L2	mm	465	465
M	mm	560	560
N	mm	180	180
h1	mm	1440	1440
h3	mm	200	200
B	mm	750	750
WA	mm	1430	1430

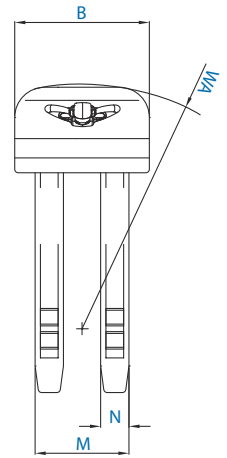
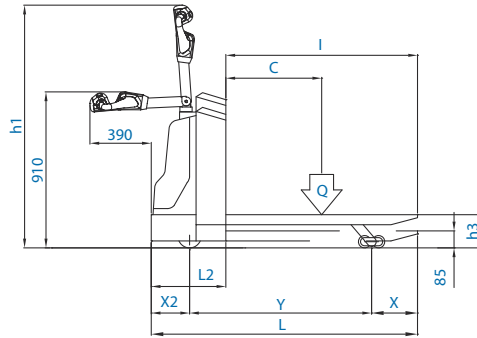

STANDARD EQUIPMENT

- AC three-phase technology traction motors (only for Smart Plus version) • Braking in release contra flow (only for Smart Light)
- High-frequency electronic plant 24V with microprocessor fault research (only for Smart Light) • Electronic plant 24V with controller with mosfet technology complete with inverter and microprocessor fault research (only for Smart Plus version) • Regenerative braking with consumption reduction and temperature control of the traction motor (only for Smart Plus version) • Electronic battery charger 24V 20A with microprocessor • Forks control by push-buttons • Electric end stroke • Proof-seal bearings with pins with self lubricating sintered bushings • Electromagnetic parking brake • Fixed forks length mm. 800-1000-1150 • Shock absorber on driving-wheel • Exhausted battery warning-indicator • Side wheels with extra-heavy castors • Tandem or single fork rollers • DR-EVO Steering • Safety components • N. 2 batteries 12V 155Ah (for Smart Plus) or N. 2 batteries 12V 120 Ah (for Smart Light); traction battery 24V 130Ah on request

SMART DL AC-evo 180/07

model		180/07
Q1	Kg	750
Q2	Kg	1800
C	mm	600
I	mm	1150
L	mm	1755
X	mm	170
X2	mm	185
Y	mm	1400
L2	mm	605
M	mm	566
N	mm	188
h1	mm	/
h3	mm	700
B	mm	750
WA	mm	1610

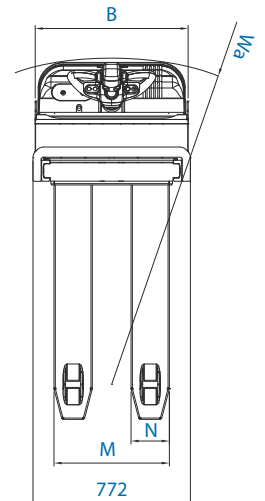
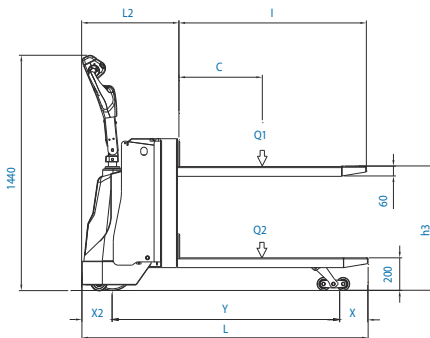

SMART DL AC-evo 180/14

model		180/14
Q1	Kg	1050
Q2	Kg	1800
C	mm	600
I	mm	1150
L	mm	1755
X	mm	170
X2	mm	185
Y	mm	1400
L2	mm	605
M	mm	566
N	mm	188
h1	mm	1170
h3	mm	1400
h4	mm	1830
B	mm	750
WA	mm	1610

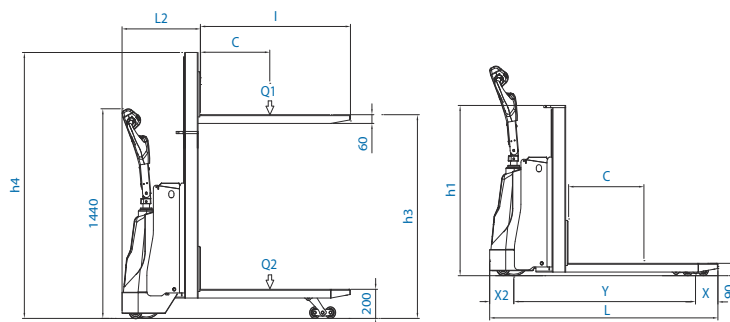

STANDARD EQUIPMENT

- AC three-phase technology traction motors • Electronic plant 24V with controller with mosfet technology complete with inverter and microprocessor fault research • Regenerative braking with consumption reduction and temperature control of the traction motor • Electronic battery charger 24V 20A with microprocessor • Forks control by push-buttons • Electric end stroke • Proof-seal bearings with pins with self lubricating sintered bushings • Electromagnetic parking brake • Fixed forks length mm. 1150 • Shock absorber on driving-wheel • Exhausted battery warning-indicator • Side wheels with extra-heavy castors • Tandem fork rollers • DR-EVO Steering • Safety components • Traction Battery 24V 130AH MBS

DISCOVERY AC-evo | DISCOVERY PE AC-evo

Excellence in handling operations

Capacity (kg): 2000 - 2500 - 3000 - 3500 - 4000 Lifting Height (mm): 200

DISCOVERY AC-evo

An extra heavy-duty structure and large industrial batteries ensure maximum reliability and safety in applications with heavy use and loads.



DISCOVERY Compact AC-evo:

Super-compact version for heavy-duty use for loads to 2000 kg in the narrowest of work spaces.

FC *technology*

- + Performance
- + Driving control
- Service Costs



DISCOVERY PE AC-evo

With load cells built into the lifting forks, an electronic weighing system offers instant weight readings for the load being handled.



Electronic Display:

The electronic display shows the exact load and easily clears to zero. Available with data printer or serial output for connection to a PC.

POWERED PALLET TRUCKS

Features in detail: _____



NEW DR EVO DRIVE STEERING:

Includes LED battery charge indicator, "turtle" switch for variable speed control, precision proportional lifting / lowering control and safety reversing (crushproof) switch.



LARGE CAPACITIES:

Extra sturdy machine body and lifting-fork structure with larger battery in models with capacity of greater than 3000 Kg.



FREEDOM FROM DOWNTIME:

Powered by 24V industrial batteries with capacities to 270 Ah. A battery charger is built-in to the stacker control housing and includes a 220VAC power cord.



TRACTION AND STABILITY:

Structure with 5 contact points and shock-absorber system for perfect grip by the driving wheel in case of floor irregularities. AC traction drives offer maximum responsiveness in starting and during braking.



DISCOVERY AC-evo

model		compact	200/200	250/200	300/200	350/200	400/200
Q	Kg	2000	2000	2500	3000	3500	4000
C	mm	600	600	600	600	600	600
I	mm	1150	1150	1150	1150	1150	1150
L	mm	1660	1705	1705	1705	1725	1795
X	mm	205	180	180	180	180	180
X2	mm	190	190	190	190	200	230
Y	mm	1265	1335	1335	1335	1345	1385
L2	mm	510	555	555	555	575	645
M	mm	560	540	540	540	572	572
N	mm	180	170	170	170	200	200
h1	mm	1440	1440	1440	1440	1440	1440
h3	mm	200	200	200	200	200	200
B	mm	750	750	750	750	750	750
WA	mm	1475	1550	1550	1550	1570	1640

STANDARD EQUIPMENT

• AC three-phase technology traction motors • Electronic plant 24V with controller with mosfet technology complete with inverter and microprocessor fault research • Regenerative braking with consumption reduction and temperature control of the traction motor • Electronic battery charger 24V 20A with microprocessor (for DISCOVERY 200-250-300 / COMPACT) • High frequency electronic battery charger 24V 40A (for DISCOVERY 350-400) • Forks control by push-buttons • Electric end stroke • Proof-seal bearings with pins with self lubricating sintered bushings • Electromagnetic parking brake • Fixed forks length mm. 800-1000-1150 • Shock absorber on driving-wheel • Exhausted battery warning-indicator • Side wheels with extra-heavy castors • Tandem fork rollers • DR-EVO Steering • Safety components • Traction Battery 24V 160AH (for DISCOVERY COMPACT) • Traction Battery 24V from 160 Ah to 270 Ah (for DISCOVERY 200-250-300) • Traction Battery 24V 240 / 270 Ah (for DISCOVERY 350-400)

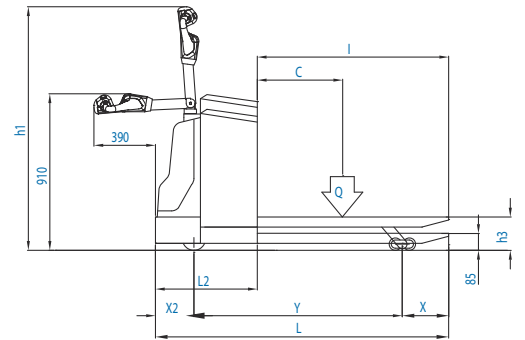
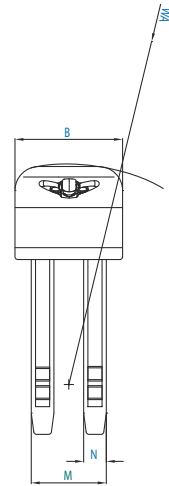

DISCOVERY PE AC-evo

model		150/200	200/200	250/200
Q	Kg	1500	2000	2500
C	mm	600	600	600
I	mm	1150	1150	1150
L	mm	1730	1730	1730
X	mm	205	205	205
X2	mm	190	190	190
Y	mm	1335	1335	1335
L2	mm	580	580	580
M	mm	554	554	554
N	mm	184	184	184
h1	mm	1440	1440	1440
h3	mm	200	200	200
B	mm	750	750	750
WA	mm	1550	1550	1550

STANDARD EQUIPMENT

• AC three-phase technology traction motors • Electronic plant 24V with controller with mosfet technology complete with inverter and microprocessor fault research • Regenerative braking with consumption reduction and temperature control of the traction motor • Electronic battery charger 24V 20A with microprocessor • Forks control by push-buttons • Electric end stroke • Proof-seal bearings with pins with self lubricating sintered bushings • Electromagnetic parking brake • Shock absorber on driving-wheel • Exhausted battery warning-indicator • Side wheels with extra-heavy castors • Tandem fork rollers • DR-EVO Steering • Electronic weighing system • Safety components • Traction Battery 24V from 160 Ah to 270 Ah

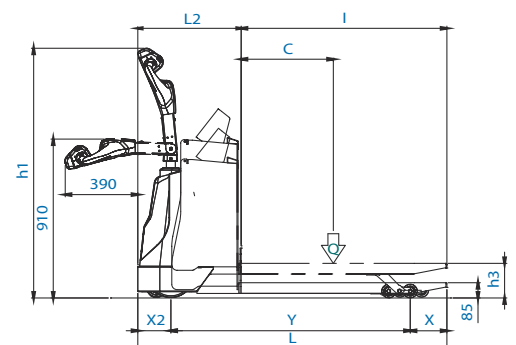
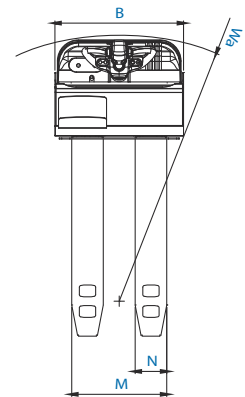

CHALLENGER AC-evo

Expert in long distances

 Capacity (kg): 1500 - 2000

 Lifting Height (mm): 200

CHALLENGER AC-evo

The ideal solution to handle the pallets in large warehouses where a high transfer speed is necessary to cover long distances.

The CHALLENGER is equipped with a folding platform and lateral safety boards to allow the operator to ride the truck in complete safety while reducing operator fatigue.



AC technology

- + Performance
- + Driving control
- Service Costs

POWERED PALLET TRUCKS

Features in detail: _____



MAXIMUM AUTONOMY:

Powered by 24V industrial batteries with capacities to 270 Ah. A battery charger is built-in to the stacker control housing and includes a 220VAC power cord.



SAFE SPEED:

High torque driving wheel is enhanced for high speeds (8 Km/h). Operator platform and side boards offer complete safety for high speed operation.

SKIPPER AC-evo | SKIPPER PLUS AC-evo

Low and average pick-up

 Capacity (kg): 1500 - 2500 - 3000

 Lifting Height (mm): 200

SKIPPER AC-evo

The operator's platform with ergonomic cushioned back rest is compact and easy to drive for goods picking or partial loads at various locations.

SKIPPER trucks are offered with custom forks for special loads or handling two pallets for even more efficient operation.

AC technology

- + Performance
- + Driving control
- Service Costs



SKIPPER PLUS AC-evo

Lifting platform version allows the operator to pick goods at increased heights.



POWERED PALLET TRUCKS

Features in detail: _____



■ Pick up goods at floor level with driver on-board.



■ Pick up goods at higher levels by lifting the operator.



CHALLENGER AC-evo

model		150/200	200/200
Q	Kg	1500	2000
C	mm	600	600
I	mm	1150	1150
L	mm	1810	1810
X	mm	180	180
X2	mm	295	295
Y	mm	1335	1335
L2	mm	660	660
M	mm	540	540
N	mm	170	170
h1	mm	1440	1440
h3	mm	200	200
B	mm	750	750
WA	mm	1660	1660
WA*	mm	2040	2040

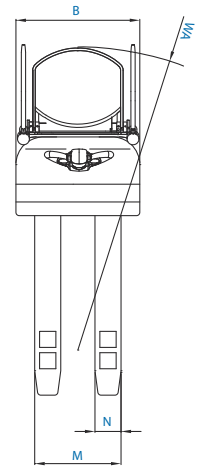
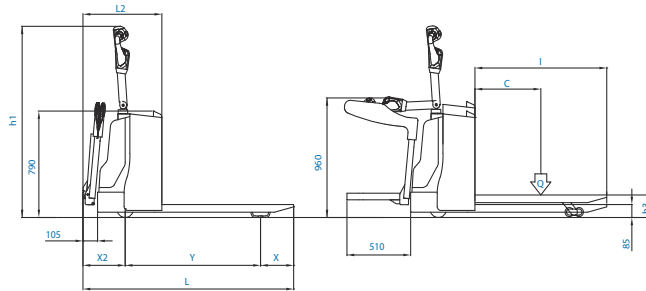

STANDARD EQUIPMENT

- AC three-phase technology traction motors • Electronic plant 24V with controller with mosfet technology complete with inverter and microprocessor fault research • Regenerative braking with consumption reduction and temperature control of the traction motor
- High frequency electronic battery charger 24V 40A • Forks control by push-buttons • Electric end stroke • Proof-seal bearings with pins with self lubricating sintered bushings • Electromagnetic parking brake • Exhausted battery warning-indicator • Faster ratio motor wheel 24V 1700W • Folding footboard for operator with side guards with speed reduction switch • Side wheels with extra-heavy castors • Tandem fork rollers • DR-EVO Steering • Safety components • Traction Battery 24V 240 / 270 Ah

SKIPPER AC-evo

model		150/200	200/200	250/200	300/200
Q	Kg	1500	2000	2500	3000
C	mm	600	600	600	600
I	mm	1150	1150	1150	1150
L	mm	2150	2150	2150	2150
X	mm	180	180	180	180
X2	mm	190	190	190	190
Y	mm	1780	1780	1780	1780
L2	mm	555	555	555	555
M	mm	540	540	540	540
N	mm	170	170	170	170
h1	mm	1440	1440	1440	1440
h3	mm	200	200	200	200
B	mm	750	750	750	750
WA	mm	2000	2000	2000	2000

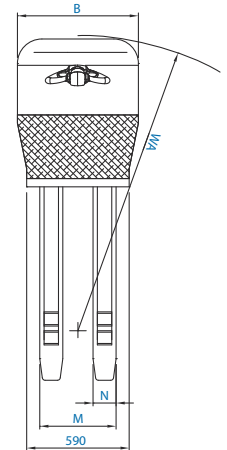
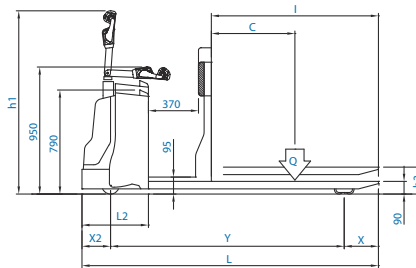

STANDARD EQUIPMENT

- AC three-phase technology traction motors • Electronic plant 24V with controller with mosfet technology complete with inverter and microprocessor fault research • Regenerative braking with consumption reduction and temperature control of the traction motor
- Electronic battery charger 24V 20A with microprocessor • Forks control by push-buttons • Electric end stroke • Proof-seal bearings with pins with self lubricating sintered bushings • Electromagnetic parking brake • Footboard for operator • Faster ratio motor wheel 24V 1700W • Side wheels with extra-heavy castors • Tandem fork rollers • DR-EVO Steering • Safety components • Traction Battery 24V from 160 Ah to 270 Ah

SKIPPER PLUS AC-evo

model		150/200	200/200	250/200	300/200
Q	Kg	1500	2000	2500	3000
C	mm	600	600	600	600
I	mm	1150	1150	1150	1150
L	mm	2150	2150	2150	2150
X	mm	180	180	180	180
X2	mm	190	190	190	190
Y	mm	1780	1780	1780	1780
L2	mm	555	555	555	555
M	mm	540	540	540	540
N	mm	170	170	170	170
h1	mm	1090	1090	1090	1090
h3	mm	200	200	200	200
B	mm	750	750	750	750
WA	mm	2000	2000	2000	2000

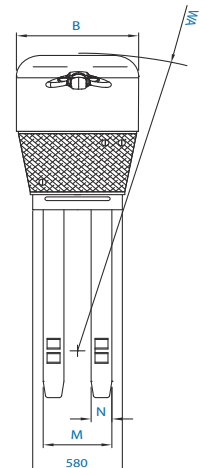
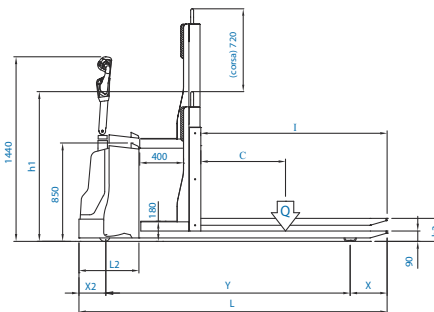

STANDARD EQUIPMENT

- AC threephase technology traction motors • Electronic plant 24V with controller with mosfet technology complete with inverter and microprocessor fault research • Regenerative braking with consumption reduction and temperature control of the traction motor
- Electronic battery charger 24V 20A with microprocessor • Forks control by push-buttons • Electric end stroke • Proof-seal bearings with pins with self lubricating sintered bushings • Electromagnetic parking brake • Footboard lifting by foot/hand push buttons • Faster ratio motor wheel 24V 1700W • Side wheels with extra-heavy castors • Tandem fork rollers • DR-EVO Steering • Safety components • Traction Battery 24V from 160 Ah to 270 Ah

MAJESTIC AC-evo

Handling operations for the fruit and vegetable industry

Capacity (kg): 1600 - 2000

Lifting Height (mm): 200

MAJESTIC AC-evo

Lateral fork movement and quick change fork extensions offer maximum efficiency and versatility to handle boxed goods, containers and pallets in the fruit and vegetable industry. Adjust the forks laterally to accommodate odd size pallets (other than traditional Euro pallets 800 mm x 1200 mm), such as 1000 mm x 1000 mm or 1000 mm x 1200 mm. The special raised fork top allows handling bulky and stacked loads quickly and safely.



Manual control increase the fork width from 550 mm to 670 mm.

FC technology
+ Performance
+ Driving control
- Service Costs



60 mm of lateral movement per fork is controlled by hand operated hydraulic valves.



SPECIAL PALLET TRUCKS

Features in detail: _____



OPPORTUNITY TO EXTEND - SHORTEN THE FORKS:

Quick installation of removable fork extensions to pick up "short" pallets (1000 mm x 1000 mm) in addition to traditional euro pallets.



LATERAL MOVEMENT:

Lateral fork movement facilitates handling of the pallet from the long or short side for storage.



WIDENING:

Increase the fork width to pick up wide pallets (1000 mm x 1200 mm) to prevent tipping or bending of the pallet when lifted.



MAJESTIC AC-evo

model		COMPACT 160/200	200/200
Q	Kg	1600	2000
C	mm	500	500
I	mm	1000+180*	1000+180*
L	mm	1540+180*	1640+180*
X	mm	190+180*	190+180*
X2	mm	185	185
Y	mm	1165	1265
L2	mm	510	575
M	mm	550/670	550/670
N	mm	180	180
h1	mm	1440	1440
h3	mm	200	200
B	mm	750	750
WA	mm	1375	1475
T	mm	60	60

* Forks extensions = 180 mm

STANDARD EQUIPMENT

- AC three-phase technology traction motors • Electronic plant 24V with controller with mosfet technology complete with inverter and microprocessor fault research • Regenerative braking with consumption reduction and temperature control of the traction motor • Electronic battery charger 24V 20A with microprocessor • Forks control by hydraulic distributor • Forks side shift by hydraulic distributor • Enlargement forks lever • Fixed forks length mm. 1000 • Forks extensions length mm. 180 • Electric end stroke • Proof-seal bearings with pins with self lubricating sintered bushings • Electro-magnetic parking brake • Shock absorber on driving-wheel • Exhausted battery warning-indicator • Side wheels with extra-heavy castors • Tandem fork rollers • DR-EVO Steering • Safety components • n.2 Battery 12V 155AH (for MAJESTIC COMPACT 160) • Traction battery 24V from 160 Ah to 270 Ah (for MAJESTIC 200)

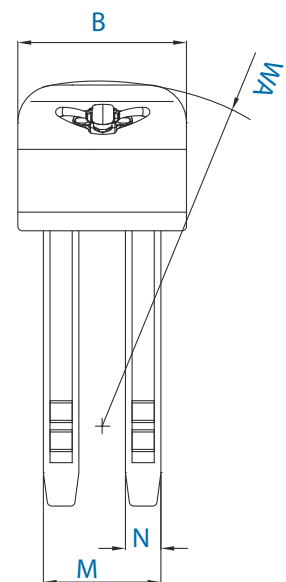
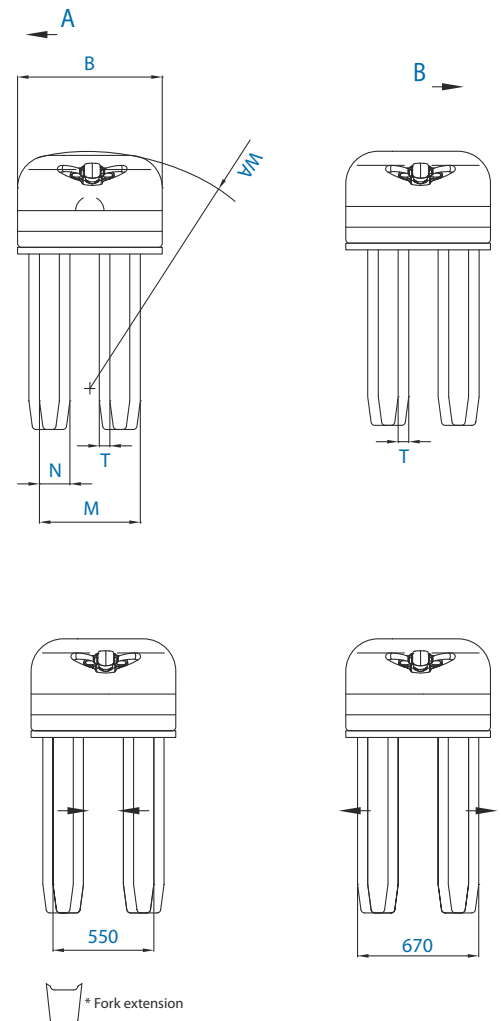
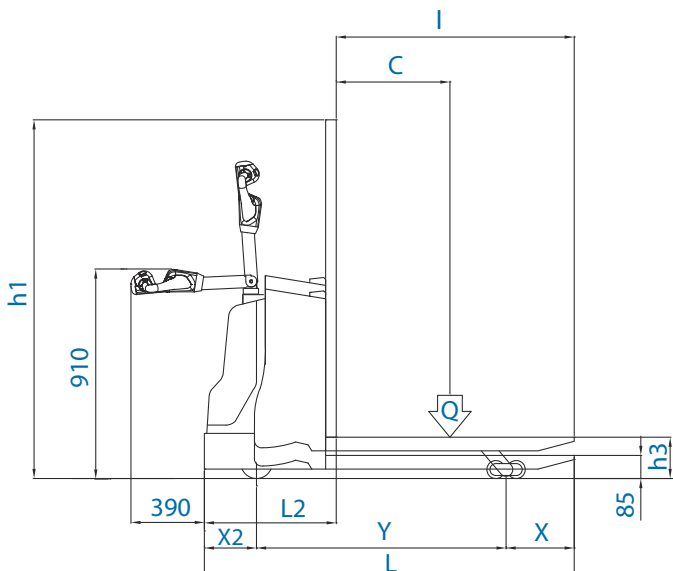

DISCOVERY PB AC-evo

Handling of reels, coils and beams

Capacity (kg): On demand Lifting Height (mm): On demand

DISCOVERY PB AC-evo

Pallet trucks with special shaped forks allow safe and efficient handling of reels, coils and beams.



AC technology

- + Performance
- + Driving control
- Service Costs



Customised Trucks:

Pallet trucks for reel, coil and beam handling are built to suit the requirements of the application. The length, width and shape of the forks, as well as the overall truck dimensions, are defined by the specific load to be handled.



DISCOVERY PB with **extra-sturdy and longer forks** to handle loads with special size and weight.



Extra-compact DISCOVERY PB with **shortened forks** to handle special loads.



DISCOVERY PB with **small lifting mast** to elevate the load from the floor.

SPECIAL PALLET TRUCKS

Features in detail: _____

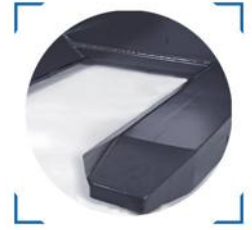

SHAPED FORKS:

Shaped forks conform perfectly to the cylindrical shape of the load.



COUNTER-FORK FRAMES:

Folding fork frames allow handling a wider range of payload diameters.



MACHINE FRAME:

The machine frame is enlarged to ensure maximum stability in case of large loads.



DISCOVERY PB In Operation:

Easy and completely safe handling of even large cylindrical loads.

TPE HL AC-evo

Handling of Special Loads

 Capacity (kg): from 5 to 20 tons  Lifting Height (mm): 200 or higher lifting on demand



*Compact version for capacities up to 7 tons

TPE HL AC-evo

Extra heavy duty electric pallet truck for safe and easy handling of loads with extreme weights and large dimensions.

Equipped with powerful 24 V or 48V traction motors, power assisted steering and electrohydraulic lift system for loads to 20 tons.



*Extra-sturdy version for capacities included between 8 tons and 20 tons

Custom Equipment:

The length, width and lifting height of the forks on HL pallet trucks, as well as the overall machine dimensions, are defined according to the specific size and weight of the loads to be handled.



TPE HL is the ideal solution for handling heavy and bulky loads in cargo areas of harbours, railway stations and airports, as well as the metal products industry for handling moulds and raw materials.

SPECIAL PALLET TRUCKS

Features in detail: _____



DRIVING AND TRACTION:

Power assisted steering and AC traction motors offer maximum power, fast acceleration and safe braking, as well as easy maneuvering in small work spaces.

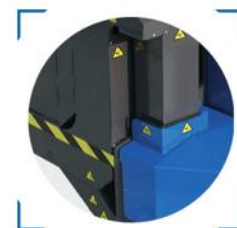

LIFTING POWER:

Special "small mast" design with double lateral pistons lift up to 20 tons.



BATTERY REPLACEMENT:

Optional roller bed system enables battery changes in minutes for minimum downtime in applications requiring continuous use.



MAXIMUM STABILITY:

Triple rollers on the side of the forks evenly distribute loads on high capacity machines.

TPT AC-evo | TPT UB AC-evo | TPT HL AC-evo

Towing Power

 Tow capacity (kg): 4000 - 5000 - 6000 - from 7000 to 20000 (HL versions)

TPT AC-evo

The safest and easiest way to tow rolling or trailed loads up to 6000 kg! Extra stability is gained from dual sets of heavy-duty front wheels. A powerful electro-hydraulic lift operates the tow hook or hitch ball.



AC technology

- + Performance
- + Driving control
- Service Costs

TPT UB AC-evo

Version with operator on board to tow four-wheel trailers; the drive with steering arm combined with the consent foot-key assure maximum safety during the handling operations.



CAPACITY
UP TO
20 TONS

POWER
ASSISTED
STEERING

* only for capacity higher than 8 ton

AC technology

- + Performance
- + Driving control
- Service Costs

TPT HL AC-evo

With an extra heavy-duty structure, 24V or 48V AC traction drive motor technology and a powerful hydraulic lift, the TPT HL makes towing extreme loads up to 20 tons safe and easy.



Customised Trucks:

HL towing trucks are manufactured to the customer's specific requirements. The tow hook or hitch coupling is designed according to the mass and loads to be handled.

TOW TRACTORS

Features in detail: _____



TOW HOOK:

Tow hooks or hitch couplings are designed specifically for the trailer or the equipment to be towed.



LIFTING POWER:

The lift height of the tow hook or hitch coupling is adjusted by a powerful hydraulic system designed for extremely heavy loads.



TOWING OF GOODS WITH WALKING OPERATOR:

Maximum versatility and manoeuvrability to tow trailered loads in tight work spaces.



TOWING OF GOODS WITH OPERATOR ON BOARD:

A ergonomic platform and cushioned back rest offer maximum comfort and safety for the operator while towing over long distances.



TPT AC-evo

model		TPT 40	TPT 50	TPT 60
T	Kg	4000	5000	6000
Q	Kg	2000	2500	3000
C	mm	700	700	700
I	mm	875	875	875
L	mm	1445	1520	1520
X	mm	130	130	130
X2	mm	210	230	230
Y	mm	1105	1160	1160
L2	mm	570	645	645
M	mm	580	580	580
h1	mm	1440	1440	1440
h3	mm	355	355	355
B	mm	750	750	750
WA	mm	1350	1420	1420

STANDARD EQUIPMENT

- AC three-phase technology traction motors • Electronic plant 24V with controller with mosfet technology complete with inverter and microprocessor fault research • Regenerative braking with consumption reduction and temperature control of the traction motor • Electronic battery charger 24V 20A with microprocessor (for TPT 40) • High frequency electronic battery charger 24V 40A (for TPT 50 and TPT 60) • Hook control by push-button • Electric end stroke • Electromagnetic parking brake • Exhausted battery warning-indicator • DR-EVO Steering • Safety components • Traction Battery 24V from 160 Ah to 270 Ah (for TPT 40) • Traction Battery 24V 240 / 270 Ah (for TPT 50 and TPT 60)

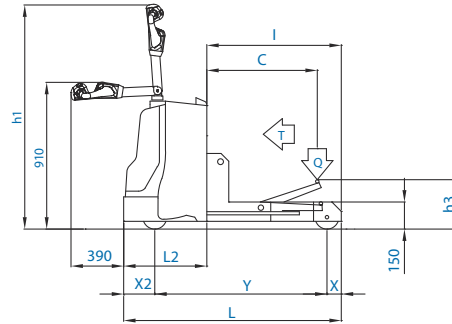
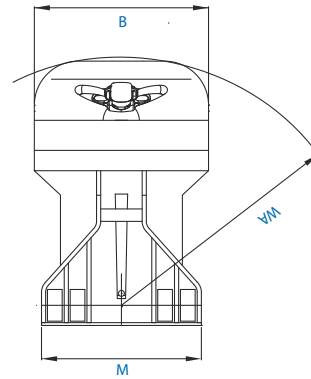

TPT UB AC-evo

model		TPT UB
T	Kg	4000
L	mm	1095
X	mm	112
X2	mm	196
Y	mm	717
L2	mm	570
M	mm	540
h1	mm	1155
B	mm	750
WA	mm	950

STANDARD EQUIPMENT

- AC three-phase technology traction motors • Electronic plant 24V with controller with mosfet technology complete with inverter and microprocessor fault research • Regenerative braking with consumption reduction and temperature control of the traction motor • Electronic battery charger 24V 20A with microprocessor • Electric end stroke • Electromagnetic parking brake • Exhausted battery warning-indicator • Footboard for operator • DR-EVO Steering • Safety components • Traction Battery 24V from 160 Ah to 270 Ah

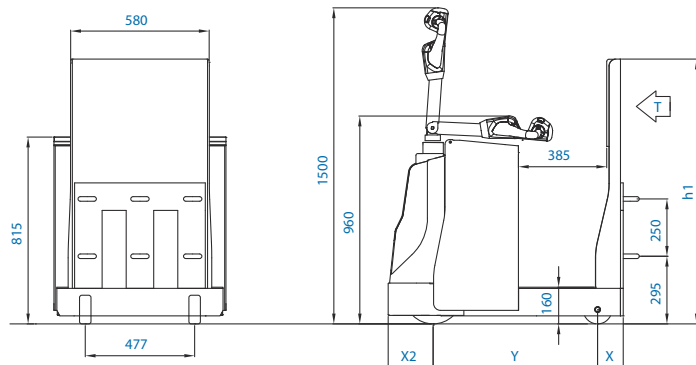
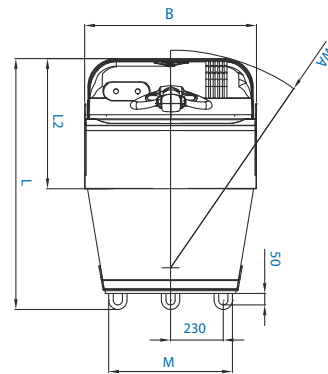

Capacity (kg): 500 - 1000 Lifting Height (mm): 1000, 1300

TM

Scissor lift with double acting hydraulic pump makes lifting and precise positioning of loads safe and easy. Ideal for use in machine shops and for handling moulds and dies.



Custom Lift Tables:
Customized lifting platforms with optional rotating or tilting tops are designed specifically for customer requirements.

Features in detail: _____



SLIDING ON BEARINGS:
Maintenance free bearings support the scissor to ensure smooth movement when lifting and lowering.



DOUBLE-ACTING MANUAL PUMP:
A double acting pump makes lifting fast and easy. Lowering by gravity is controlled by a hand operated valve in the pump body.

GAMMA 800 M | GAMMA 800 12V

Help for machine tool operators

Capacity (kg): 800 Lifting Height (mm): 1475

GAMMA 800 12V

A 12 V battery powered hydraulic lift with central piston changes elevation of the table up to 1475 mm. The GAMMA 800 is ideal as a workbench or service platform for machine tools.



GAMMA 800 M
Manual version with lift powered by a double acting hydraulic pump.

Features in detail: _____



PUSH HANDLES:
Ergonomic handlebar for ease of motion and rear swivel casters with foot operated parking brake.



CONTROLS (GAMMA 800 12V):
Platform lifting and lowering by means of specific buttons; emergency stop button for the maximum safety.



TM

model	A	B	H1	H2	S	CAPACITY (Kg)
TM / 5	600	1200	335	1000	665	500
TM / 5	800	1600	335	1300	965	500

model	A	B	H1	H2	S	CAPACITY (Kg)
TM / 10	600	1200	335	1000	665	1000
TM / 10	800	1600	335	1300	965	1000

STANDARD EQUIPMENT

- Pins mounted on sintered bushings • Chromed oleo dynamic piston • Lifting by manual double acting pump • Descent by handwheel • Polyamide wheels with polyurethane covering • Manual traction • Safety components

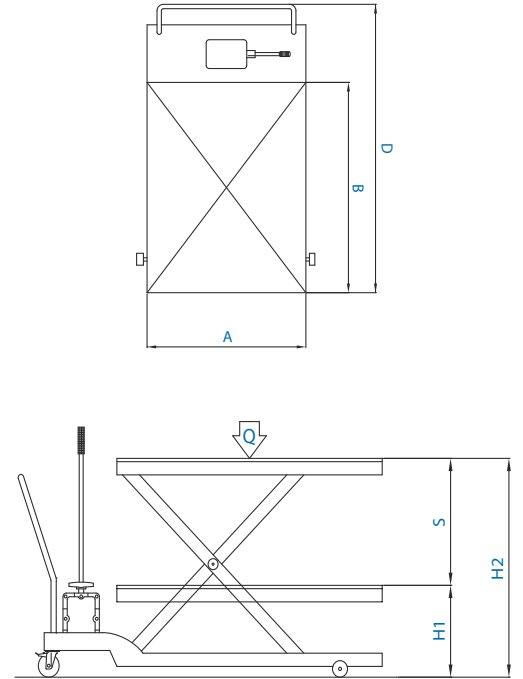

GAMMA 800 12V

model	GAMMA 800 12V	
Q	Kg	800
C	mm	400
I	mm	800
L	mm	980
X	mm	90
X2	mm	190
Y	mm	700
L2	mm	620
M-B	mm	750
h1	mm	700
h3	mm	1475
WA	mm	925

STANDARD EQUIPMENT

- Built-in electronic battery charger 12V 10A with microprocessor • Pins mounted on sintered bushings • Chromed oleo dynamic piston • Lifting and lowering by push-buttons • Polyamide wheels with polyurethane covering • Manual traction • Safety components • Emergency push button • Battery 12V 100 Ah

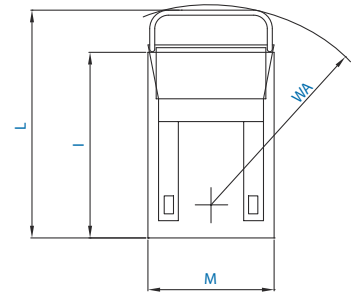
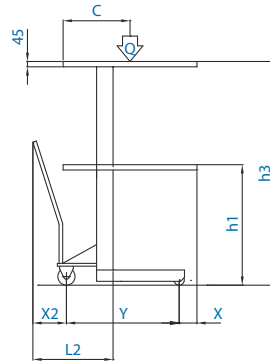

GAMMA 800 M

model	GAMMA 800M	
Q	Kg	800
C	mm	400
I	mm	800
L	mm	980
X	mm	90
X2	mm	190
Y	mm	700
L2	mm	620
M-B	mm	750
h1	mm	700
h3	mm	1475
WA	mm	925

STANDARD EQUIPMENT

- Pins mounted on sintered bushings • Chromed oleo dynamic piston • Lifting by manual double acting pump • Descent by handwheel • Polyamide wheels with polyurethane covering • Manual traction • Safety components

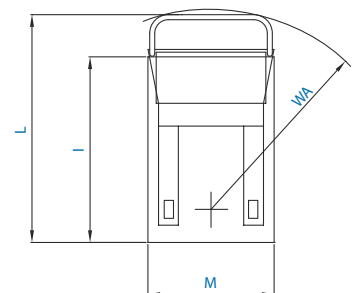
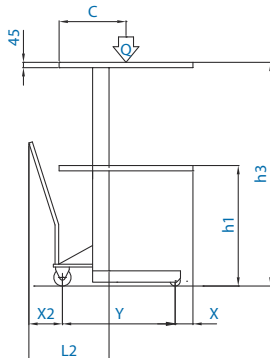

TE Electric Lift

- Capacity (kg): from 500 to 5000 (higher capacity on demand)
- Lifting Height (mm): from 950 to 2150 (higher lifting on demand)

TE

High capacity hydraulic scissor lift table with 380/220 VAC three-phase power pack is ideal for loading or unloading goods from motor vehicles, connecting between work planes and servicing machine tools.



TE PLUS

Double scissor version to reach high elevations without increasing the overall dimensions of the lifting platform.

CUSTOMIZED ELECTRONIC LIFT TABLES



Double scissor connected "in parallel" and extra sturdy loading platform to carry up to 10 tons.



Gates, barriers and safety sensors comply with all operator safety rules.



Lift tables combined with powered pallet trucks offer ease of movement.



Optional power systems to tilt, rotate or slide the lifting platform.

ELECTRIC LIFT TABLES

Features in detail: _____



CONTROL DEVICES:

Foot pedals, joystick or hand-held pendant with emergency stop button control lifting and lowering functions.



SLIDING ON BEARINGS:

Maintenance free bearings support the scissor to ensure smooth movement when lifting and lowering.

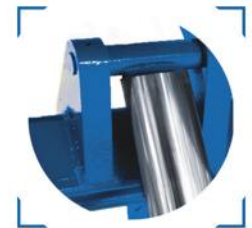

STRENGTH AND RELIABILITY:

Rigid welded-steel frames, self lubricating pivot bearings and chrome plated hydraulic cylinder rods offer long life and trouble free operation.



SAFETY PERIMETER:

Sensors at the bottom of the platform detect a person or obstacle in the work area and immediately stop the operation.



TE

model	A	B	H1	H2	S	CAPACITY (Kg)
TE / 5	600	1200	250	950	700	500
TE / 5	800	1200	250	950	700	500
TE / 5	800	1600	250	1200	950	500
TE / 5	1000	1200	250	950	700	500
TE / 5	1000	2000	350	1500	1150	500
TE / 5	1250	2500	400	1850	1450	500
TE / 5	1500	3000	400	2150	1750	500

model	A	B	H1	H2	S	CAPACITY (Kg)
TE / 10	600	1200	250	950	700	1000
TE / 10	800	1200	250	950	700	1000
TE / 10	800	1600	250	1200	950	1000
TE / 10	1000	1200	250	950	700	1000
TE / 10	1000	2000	350	1500	1150	1000
TE / 10	1250	2500	400	1850	1450	1000
TE / 10	1500	3000	400	2150	1750	1000

model	A	B	H1	H2	S	CAPACITY (Kg)
TE / 15	1000	1200	300	1000	700	1500
TE / 15	1000	1600	300	1250	950	1500
TE / 15	1000	2000	350	1500	1150	1500
TE / 15	1200	1800	300	1350	1050	1500
TE / 15	1250	2500	400	1850	1450	1500
TE / 15	1400	2000	400	1550	1150	1500
TE / 15	1500	3000	400	2150	1750	1500
TE / 15	2000	3000	400	2150	1750	1500

model	A	B	H1	H2	S	CAPACITY (Kg)
TE / 20	1000	1200	300	1000	700	2000
TE / 20	1000	1600	300	1250	950	2000
TE / 20	1000	2000	350	1500	1150	2000
TE / 20	1200	1800	350	1400	1050	2000
TE / 20	1250	2500	400	1850	1450	2000
TE / 20	1400	2000	400	1550	1150	2000
TE / 20	1500	3000	400	2150	1750	2000
TE / 20	2000	3000	400	2150	1750	2000

model	A	B	H1	H2	S	CAPACITY (Kg)
TE / 25	1000	1200	300	1000	700	2500
TE / 25	1000	1600	300	1250	950	2500
TE / 25	1000	2000	350	1500	1150	2500
TE / 25	1200	1800	350	1400	1050	2500
TE / 25	1250	2500	400	1850	1450	2500
TE / 25	1400	2000	400	1550	1150	2500
TE / 25	1500	3000	400	2150	1750	2500
TE / 25	2000	3000	400	2150	1750	2500

model	A	B	H1	H2	S	CAPACITY (Kg)
TE / 30	1000	1200	350	1050	700	3000
TE / 30	1000	1600	350	1300	950	3000
TE / 30	1000	2000	400	1550	1150	3000
TE / 30	1200	1800	400	1450	1050	3000
TE / 30	1400	2000	400	1550	1150	3000
TE / 30	1250	2500	450	1900	1450	3000
TE / 30	1500	3000	450	2200	1750	3000
TE / 30	2000	3000	450	2200	1750	3000

model	A	B	H1	H2	S	CAPACITY (Kg)
TE / 40	1000	1200	500	1200	700	4000
TE / 40	1000	1600	500	1450	950	4000
TE / 40	1000	2000	500	1650	1150	4000
TE / 40	1200	1800	500	1550	1050	4000
TE / 40	1400	2000	500	1650	1150	4000
TE / 40	1250	2500	500	1950	1450	4000
TE / 40	1500	3000	500	2250	1750	4000
TE / 40	2000	3000	500	2250	1750	4000

model	A	B	H1	H2	S	CAPACITY (Kg)
TE / 50	1000	1200	550	1250	700	5000
TE / 50	1000	1600	550	1500	950	5000
TE / 50	1000	2000	550	1700	1150	5000
TE / 50	1200	1800	550	1600	1050	5000
TE / 50	1400	2000	550	1700	1150	5000
TE / 50	1250	2500	550	2000	1450	5000
TE / 50	1500	3000	550	2300	1750	5000
TE / 50	2000	3000	550	2300	1750	5000

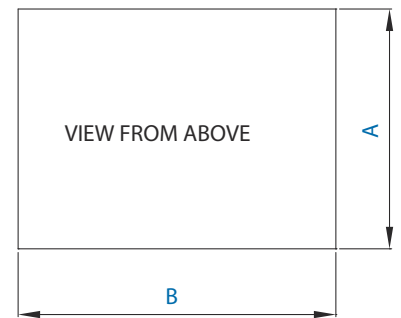
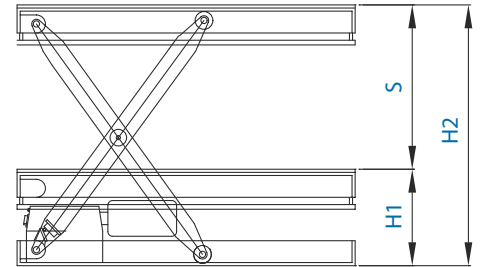

STANDARD EQUIPMENT

- Hydraulic power plant 380/220V
- Pins mounted on sintered bushings
- Chromed oleo dynamic piston
- Lifting and lowering by push-buttons
- Slide on bearings
- Strong electro welded steel frame
- Safety perimeter



ARMANNI CUSTOMIZED SOLUTIONS

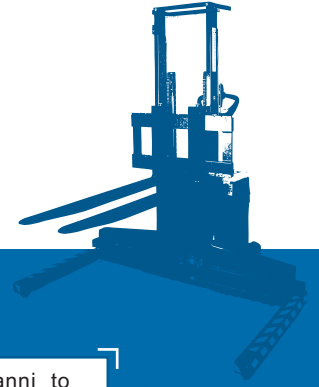

More than 40 years of experience in this industry allow Armani to offer maximum competence and effectiveness in the manufacturing of customised lift trucks, which are developed together with the customer according to individual and dedicated designs.



Our practical **PROBLEM SOLVING** attitude enables us transforming any handling problem in a success: our design team is responsible to inspect and analyze the problem with you, finding the best solution to make safer and more efficient your work and finally developing rigorous feasibility and construction studies to realize the project developed together. The perfect marriage between the strict application of the principles of mechanical engineering and the constant attention to technological innovation allows us providing solutions perfectly sized and equipped to safely deal with even the most complex problems.



GUIDING PRINCIPLES:

Problem solving mentality

to turn your problem into a successful solution

Direct management of the Production Process

to ensure the utmost professionalism from design to production to continuing support

One hundred percent Italian made

to express the total quality and reliability of Italian products

Ability to combine functionality and design

to envelope efficiency, ergonomics and aesthetics into one product

Technological Innovation

to offer the most advanced products available on the market

Personalized responses

to ensure specific and unique solutions to an increasingly articulate and demanding market



STAINLESS STEEL LIFT TRUCKS

Duration and Efficiency also in the harshest conditions

SPECIAL PRODUCTION

Complete range of stackers and pallet trucks manufactured with stainless steel to handle goods within working premises that are characterised by a high presence of humidity, condensate, dusts and saline solutions. For this reason, the aforesaid machines are particularly subject to oxidation phenomena and need solutions that are characterised by specific materials and construction features to assure long duration and efficiency in time.



STAINLESS STEEL DRIVE STEERING

Drive steering that is completely made of stainless steel and watertight buttons.

STAINLESS STEEL STACKERS

Manual, semi-electric or fully powered stackers in fully stainless steel version.



ALFA M Inox
Q (kg): 500 - 1000
H (mm): 800, 1600
Fully stainless steel



BETA 12V Inox
Q (kg): 1000 - 1200
H (mm): 1600, 2500, 3000, 3500
Fully stainless steel



SPEEDY Inox
Q (kg): 1000 H (mm): 1600
MASTER Inox
Q (kg): 1000/1200
H (mm): 2900/2500-3000



DELTA Inox
Q (kg): 1200 - 1400
H (mm): 1600, 2500, 3000, 3500
Fully stainless steel

STAINLESS STEEL PALLET TRUCKS

Hand or fully powered pallet trucks in fully stainless steel version.



TPM Inox
Q (kg): 2000
H (mm): 200
Fully stainless steel



TPM GAL M Inox
Q (kg): 1000
H (mm): 800
Fully stainless steel



TPM GAL 12V Inox
Q (kg): 1000
H (mm): 800
Fully stainless steel



SMART Inox / DISCOVERY Inox
Q (kg): 1500-2000 / 2000
H (mm): 200
Fully stainless steel
(only for DISCOVERY)

STAINLESS STEEL CUSTOM SOLUTIONS

Manufacturing of special stainless steel machines in case of specific needs of the customer; optional equipment with specific stainless steel appliances to handle reels, coils, drums, tanks and containers in general.



REEL, COIL AND BEAM HANDLING

Special solutions for ground handling or the lifting at specific heights of reels, coils and beams of various sizes, weights and type of material.

CRADLE FORKS/
HORIZONTAL PROBES



FIXED OR TILTING
CRADLES



ROTATING CLAMPS and
SHAFT REEL TURNER



DRUMS HANDLING

Stackers equipped with mechanical or hydraulic control designed for picking, storage, transport, tipping and emptying of the barrels, casks, drums and containers in general characterized by a cylindrical shape.

FRONT & SIDE RING
CLAMP DRUM TURNERS



LIFTING CLAMP
DRUM TURNERS



INDUSTRIAL CONTAINER HANDLING

Special equipment for handling and possible tipping and emptying of industrial containers of various sizes such as cases and plastic boxes, stackable baskets made of iron, sheet metal boxes and industrial containers in general.

FRONT & SIDE
TILTERS



CLAMP LIFTERS & TILTERS



CUSTOM SOLUTIONS

Sole solutions starting from the Customer needs; the careful analysis of the characteristics of the working environment, the handling space, the size and shape of the load to handle allows the realisation of trucks which are perfectly able to integrate to the diversified production realities.



Some possible customized solutions:

FORKS: extended-shortened - widened- adjustable- widened carriage - forks side shift and positioner

LEGS: widened - tightened - extended - shortened- extra strong

FRAME: widened base - narrow base - extended/shortened mast - side stabilizers - platform for operator



Disset Odiseo
900 17 17 00 · 93 586 15 60
comercial@dissetodiseo.com